

Calibrating CMB Polarization Telescopes

S. T. Staggs*, D. Barkats*, J. O. Gundersen[†], M. M. Hedman*, C. Herzog*, J. J. McMahon* and B. Winstein**

*Physics Department, Princeton University, Princeton, NJ, 08544

[†]Department of Physics, University of Miami, Coral Gables, FL, 33146

**Department of Physics and the Enrico Fermi Institute, University of Chicago, Chicago, IL, 60637

Abstract. Instruments for measuring the polarization of the cosmic microwave background (CMB) must be designed for accuracy as well as precision. The requirement for precision translates into a need for detectors with unprecedented sensitivity. Accuracy requires good methods for calibrating the response of the instrument to small polarized signals superimposed on large unpolarized signals. Since well-characterized polarized astrophysical millimeter sources are in short supply, we present an alternative method here. A flat metal plate is mounted in front of the telescope and nutated about a vertical axis, providing a varying polarized signal of amplitude near 30 mK.

INTRODUCTION

The polarization of the cosmic microwave background promises to provide new and interesting information about the structure and dynamics of the early universe. There has been a recent surge of interest in measuring this elusive polarized signal, and a suite of highly sensitive polarimeters are now being used to search for the cosmological polarization. Calibrating these polarimeters is a significant challenge. In the absence of bright, well-characterized astrophysical point sources, specialized techniques are needed to generate polarized signals. This paper described the use of a nutating metal plate to calibrate the Princeton IQU Experiment (PIQUE). Related techniques using dielectric sheets and wire grids are described in Keating et al., 2001 [5].

STOKES PARAMETERS

In order to calibrate a polarimeter, the polarization state of the incident electromagnetic radiation must be consistently defined using the Stokes parameters I , Q and U (a fourth parameter V measures the circularly polarized component of the radiation). These parameters are defined in terms of two orthogonal components of the electric field E_x and E_y :

$$I = \langle E_x^2 \rangle + \langle E_y^2 \rangle, \quad (1)$$

$$Q = \langle E_x^2 \rangle - \langle E_y^2 \rangle, \quad (2)$$

$$U = \langle 2E_x E_y \rangle. \quad (3)$$

These parameters are the basis of all recent treatments (e.g. [1],[2],[4]) of the theoretical predictions of the CMB. As defined above, the Stokes parameters have units of intensity/ c , where c is the speed of light. Because the CMB is observed to be an excellent blackbody, its intensity is uniquely determined by its temperature. Therefore, the convention in CMB experiments is to express measurements in units of temperature. The Stokes parameters with units of temperature are denoted here T , Q_T and U_T . The parameter T is related to I by a units-conversion factor: $T = \hat{k}I$. To maintain consistent definitions of the Stokes parameters, the same factor \hat{k} must be used to define Q_T and U_T : $Q_T = \hat{k}Q$ and $U_T = \hat{k}U$.

Many CMB receivers operate with scalar feed horns coupled to waveguide and are thus sensitive to only one polarized component (e.g., E_x or E_y) of the radiation field at a time. The power carried in one such component is

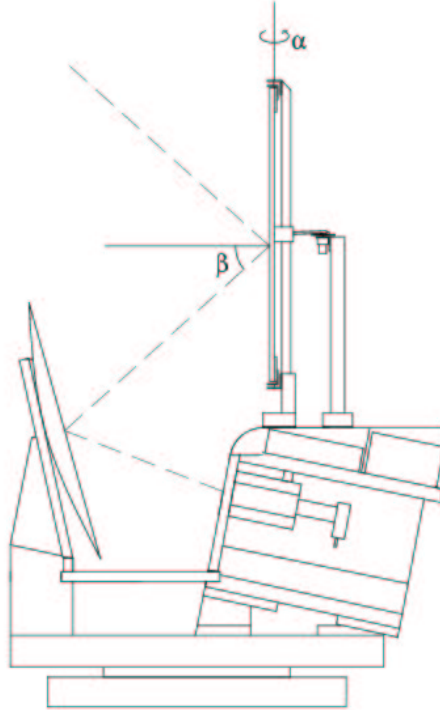

FIGURE 1. A figure showing the geometry of the calibrator plate used for PIQUE. The PIQUE optics comprise a 1.2 m off-axis parabola coupling to a scalar feed horn. The experiment is designed to operate at fixed elevation to observe near the North Celestial Pole (NCP). For calibration, the instrument is rotated by 180° in azimuth; then the additional reflection off the chopping plate results in observations once again near the NCP.

often used to estimate I or T in CMB experiments. This is reasonable since the CMB is largely unpolarized, but when the polarization is the parameter of interest, equating the power in one orthogonal component ($\propto |E_x|^2$, e.g.) with T of the CMB may cause confusion. Suppose two receivers measure two orthogonal components of the electric field, yielding two different estimates of the effective temperature, T_x and T_y . One might be tempted to equate Q_T with the difference between these two estimates, $Q_T = T_x - T_y$, but this is incorrect. Such a calculation is analogous to equating T with the sum of the two estimates, $T = T_x + T_y$. Of course, the correct expression for T is the average of the two estimates, $T = (T_x + T_y)/2$, and similarly the correct expression for Q_T is $Q_T = (T_x - T_y)/2$.

CALIBRATION WITH A NUTATING METAL PLATE

PIQUE is a correlation polarimeter that observed the sky around 90 GHz with a quarter-degree beam [6]. In its second year, PIQUE made observations with two receivers, one at 90 GHz and the other at 40 GHz. The polarimeter is calibrated using a nutating aluminum plate to provide a controlled polarized signal for the radiometer. The thermal emission from this plate and the radiation from the sky reflected off this plate are weakly polarized because of the finite conductivity of aluminum. This effect has been described in several places; a recent treatment may be found in Cortiglioni, 1994 [3].

From classical electrodynamics, it can be shown that the reflection coefficients of radiation polarized parallel ($R_{//}$) or normal (R_{\perp}) to the plane of incidence is given by (assuming the conductivity is high):

$$R_{//} = 1 - 2\delta/\lambda \sec\theta, \quad (4)$$

$$R_{\perp} = 1 - 2\delta/\lambda \cos\theta, \quad (5)$$

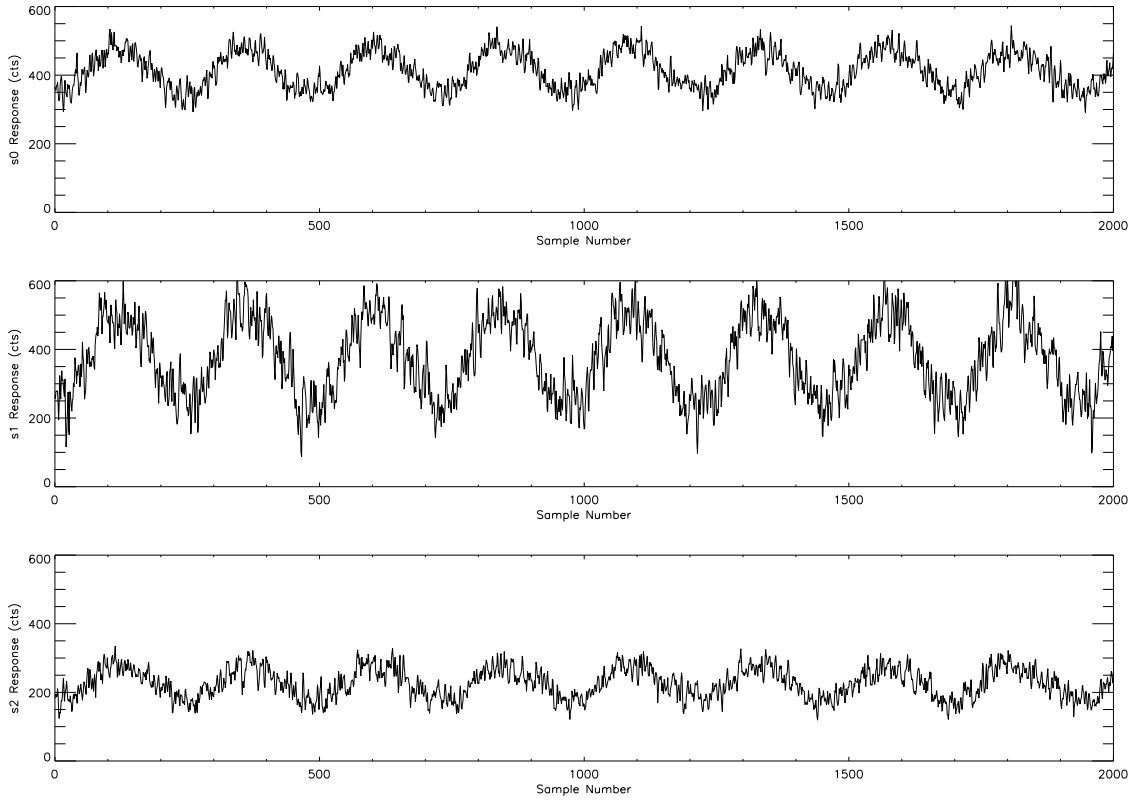

FIGURE 2. Response of PIQUE polarimetry channels to the nutating plate. The output of the three polarimetry channels are displayed as a function of time – data are sampled at 62.5 Hz. The oscillations have a period on the order of seconds.

where θ is the angle of incidence, δ is the skin depth, λ is the wavelength of the radiation, all in mks units. The fact that these two reflection coefficients have different dependencies on the incident angle means that initially unpolarized radiation reflected from the plate will acquire a polarized component dependent on the orientation of the plate. It follows from Kirchoff's law that the thermal emission of the plate will also be polarized, and that the polarized component will have the opposite sign (i.e. if the reflected radiation has a positive Q , the emitted radiation will have a negative Q).

The size of the polarized signal from the plate depends on the orientation of the plate with respect to the detector. The geometry of the PIQUE calibrator is shown in Figure 1. The ray from the feed horn at the focus of the parabola arrives at the plate at an elevation angle $\beta \simeq 41^\circ$ (after reflecting once off the parabola). The vector normal to the plate makes an angle α with the vertical plane bisecting the telescope. The plate nutates about a vertical axis, so α oscillates sinusoidally in time as $\alpha = \alpha_o \cos(\omega_o t + \phi)$, where typical values for the amplitude and the frequency are $\alpha_o \simeq 5^\circ$ and $\omega_o \sim 1$ Hz.

Given this geometry, one can calculate how the polarized signal Q_T introduced into the receiver will vary as a function of α (assuming α small):

$$Q_T(\alpha) = \kappa \frac{\alpha}{\alpha_o} (T_{plate} - T_{sky}), \quad (6)$$

where T_{plate} and T_{sky} are the physical temperature of the plate and the effective noise temperature of the sky (including the atmosphere, the CMB, and any Galactic signals). The dependencies on the composition and the geometry of the plate are included in the dimensionless parameter κ :

$$\kappa = 2 \frac{\delta}{\lambda} \gamma \frac{\sec \beta - \cos \beta}{\sin \beta} \alpha_o. \quad (7)$$

The factor γ in this expression is a factor that accounts for how much of the telescope beam intersects the plate. If the plate is small and uniformly illuminated $\gamma = \sec \beta$, but if the plate is infinitely large $\gamma = 1$. For PIQUE at 90 GHz, only 3% of the beam spills past the chopping plate, so γ can be reasonably approximated as unity.

Inserting the correct expressions for the skin depth, wavelength and relevant angles, one finds that $\kappa \simeq 10^{-4}$. Therefore, if $T_{plate} \simeq 300\text{K}$ and $T_{sky} \simeq 50\text{K}$, the polarized signal injected into the telescope varies with an amplitude of about 30 mK.

When the plate is installed and begins nutating, the outputs from the polarimetry channels show clear sinusoidal oscillations, as shown in Figure 2. By comparing the amplitudes of these oscillations with the calculations for the polarized signals introduced by the nutating plate, the responsivity of the telescope can be determined. This requires estimates of T_{plate} and T_{sky} . The plate temperature is measured using a thermometer attached to the plate itself, while the sky temperature must be derived from the output of the total power channels in PIQUE. The accuracy of the nutating plate method has been confirmed by independent tests using calibrated cryogenic loads. These tests are tedious and require partial disassembly of the instrument. The leading uncertainty in the nutating plate calibration is the DC conductivity σ of the aluminum; a conservative estimate of 20% uncertainty on σ gives rise to an overall calibration uncertainty of 10%. We plan to measure the conductivity in separate tests and to replace the aluminum plate with a stainless steel plate as final checks. In summary, the nutating plate provides a dependable means of calibrating PIQUE at regular intervals in the field.

REFERENCES

1. Zaldarriaga, M., and Seljak, U., *Phys. Rev. D*, **55** (1997).
2. Kamionkowski, M., Kosowsky, A., and Stebbins, A., *Phys. Rev. D*, **55** (1997).
3. Cortiglioni, S., *Rev. Sci. Instrum.*, **65** (1994).
4. Zaldarriaga, M., *ApJ*, **503**, 1 (1998).
5. Keating, B. G., O'Dell, C. W., Gundersen, J. O., Piccirillo, L., Stebor, N. C., and Timbie, P., An instrument for investigating the large angular scale polarization of the cosmic microwave background (2001), [astro-ph/0111276](#).
6. Hedman, M. M., Barkats, D., Gundersen, J. O., Staggs, S. T., and Winstein, B., *ApJL*, **548**, L111–L114 (2001).