

Reflection of a Gaussian Optical Beam by a Flat Mirror

Kirk T. McDonald

Joseph Henry Laboratories, Princeton University, Princeton, NJ 08544

(October 5, 2009)

1 Problem

Discuss the flow of energy, including possible angular momentum in the flow, of a weakly focused Gaussian laser beam that reflects off a flat, perfectly conducting mirror. You may assume that the waist/focal point of the beam lies in the plane of the mirror.

2 Solution

We will use the time-average Poynting vector, $\langle \mathbf{S} \rangle = \text{Re}(\mathbf{E} \times \mathbf{B}^*)/2\mu_0 = c\epsilon_0 \text{Re}(\mathbf{E} \times c\mathbf{B}^*)/2$ (in SI units, where c is the speed of light in vacuum), to discuss the flow of energy in waves with electric field \mathbf{E} and magnetic field \mathbf{B} , assuming these waves to be in vacuum.

2.1 Reflection of an Infinite Plane Waves by a Planar Mirror

Before turning to the more realistic case of reflection of a beam with limited transverse extent, we consider the reflection by a perfectly conducting surface in the plane $z = 0$ of a plane wave of angular frequency ω that is polarized in the x -direction. The waves propagate in vacuum in the region $z < 0$.

If the incoming wave had zero angle of incidence its fields could be written (for $z < 0$)

$$E_x = E_0 e^{i(kz - \omega t)}, \quad E_y = E_z = 0, \quad B_x = 0, \quad cB_y = E_x, \quad B_z = 0, \quad (1)$$

where $k = \omega/c$ and c is the speed of light in vacuum. The energy flow in this wave is described by the (real) Poynting vector

$$\mathbf{S} = c\epsilon_0 \text{Re}\mathbf{E} \times \text{Re}\mathbf{B} = c\epsilon_0 E_0^2 \cos^2(kz - \omega t) \hat{\mathbf{z}}, \quad (2)$$

whose time average,

$$\langle \mathbf{S} \rangle = \frac{c\epsilon_0}{2} \text{Re}(\mathbf{E} \times c\mathbf{B}^*) = c\epsilon_0 \frac{E_0^2}{2} \hat{\mathbf{z}}, \quad (3)$$

is the product of the wave velocity $c\hat{\mathbf{z}}$ and the time-average energy density $\langle u \rangle = \epsilon_0 E_0^2/2$.

We now consider that case that the incident beam has angle of incidence θ in the y - z plane. We anticipate that the reflected beam also makes angle θ to the z -axis.

The incident and reflected beams each have the form (1) with respect to axes (x_i, y_i, z_i) and (x_r, y_r, z_r) , where the z_i - and z_r -axes are in the directions of propagation of the two beams.

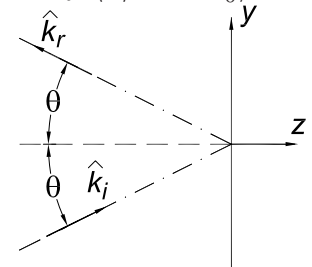

The transformation between the axes (x_i, y_i, z_i) of the incident beam and the laboratory axes (x, y, z) is

$$x_i = x, \quad y_i = y \cos \theta - z \sin \theta, \quad z_i = y \sin \theta + z \cos \theta, \quad (4)$$

and the components of a vector \mathbf{A} with respect to the laboratory frame are related to those with respect to axes (x_i, y_i, z_i) by

$$A_x = A_{x_i}, \quad A_y = \cos \theta A_{y_i} + \sin \theta A_{z_i}, \quad A_z = -\sin \theta A_{y_i} + \cos \theta A_{z_i}. \quad (5)$$

Combining eqs. (1), (4) and (5), the components of the fields of the incident wave in the laboratory frame are (for $z < 0$)

$$E_{ix} = E_0 e^{i(ky \sin \theta + kz \cos \theta - \omega t)}, \quad E_{iy} = E_{iz} = 0, \quad (6)$$

$$B_{ix} = 0, \quad cB_{iy} = E_{ix} \cos \theta, \quad cB_{iz} = -E_{ix} \sin \theta. \quad (7)$$

Similarly, the reflected beam is related by the transformations

$$x_r = x, \quad y_r = -y \cos \theta - z \sin \theta, \quad z_r = y \sin \theta - z \cos \theta, \quad (8)$$

and

$$A_x = A_{x_r}, \quad A_y = -\cos \theta A_{y_r} + \sin \theta A_{z_r}, \quad A_z = -\sin \theta A_{y_r} - \cos \theta A_{z_r}, \quad (9)$$

such that the laboratory-frame field components are (for $z < 0$)

$$E_{ir} = E_{0r} e^{i(ky \sin \theta - kz \cos \theta - \omega t)}, \quad E_{ry} = E_{rz} = 0, \quad (10)$$

$$B_{rx} = 0, \quad cB_{ry} = -E_{rx} \cos \theta, \quad cB_{rz} = -E_{rx} \sin \theta. \quad (11)$$

The boundary conditions at the perfectly conducting surface $z = 0$ are that the total electric field have no tangential component ($E_x = 0 = E_y$) and that the total magnetic field have no normal component ($B_z = 0$). All of these conditions are satisfied by

$$E_{0r} = -E_0, \quad (12)$$

which is often expressed by saying that the reflected beam has a 180° phase change with respect to the incident beam.

Combining eqs. (6)-(7), (10)-(11) and (12), the total field components are (for $z < 0$)

$$E_x = 2iE_0 e^{i(ky \sin \theta - \omega t)} \sin(kz \cos \theta), \quad E_y = E_z = 0, \quad (13)$$

$$B_x = 0, \quad cB_y = 2E_0 e^{i(ky \sin \theta - \omega t)} \cos \theta \cos(kz \cos \theta), \quad (14)$$

$$cB_z = -2iE_0 e^{i(ky \sin \theta - \omega t)} \sin \theta \sin(kz \cos \theta).$$

The time-average Poynting vector is

$$\langle \mathbf{S}(z < 0) \rangle = 2c\epsilon_0 E_0^2 \sin \theta \sin^2(kz \cos \theta) \hat{\mathbf{y}}, \quad (15)$$

which corresponds to a (steady) flow of energy in the y -direction, parallel to the mirror for any nonzero value of the angle of incidence θ . This flow is modulated in z according to $\sin^2(kz \cos \theta)$.

We could also decompose the total Poynting vector as

$$\begin{aligned}
\langle \mathbf{S} \rangle &= \frac{c \epsilon_0}{2} \text{Re}(\mathbf{E} \times c\mathbf{B}^*) = \frac{c \epsilon_0}{2} \text{Re}[(\mathbf{E}_i + \mathbf{E}_r) \times (c\mathbf{B}_i^* + c\mathbf{B}_r^*)] \\
&= \frac{c \epsilon_0}{2} \text{Re}(\mathbf{E}_i \times c\mathbf{B}_i^*) + \frac{c \epsilon_0}{2} \text{Re}(\mathbf{E}_r \times c\mathbf{B}_r^*) + \frac{c \epsilon_0}{2} \text{Re}[(\mathbf{E}_i \times c\mathbf{B}_r^*) + (\mathbf{E}_r \times c\mathbf{B}_i^*)] \\
&= \langle \mathbf{S}_i \rangle + \langle \mathbf{S}_r \rangle + \langle \mathbf{S}_{\text{int}} \rangle.
\end{aligned} \tag{16}$$

Recalling eq. (3) we have that (for $z < 0$)

$$\langle \mathbf{S}_i \rangle = c \epsilon_0 \frac{E_0^2}{2} \hat{\mathbf{k}}_i, \quad \langle \mathbf{S}_r \rangle = c \epsilon_0 \frac{E_0^2}{2} \hat{\mathbf{k}}_r, \quad \text{and} \quad \langle \mathbf{S}_i \rangle + \langle \mathbf{S}_i \rangle = c \epsilon_0 E_0^2 \sin \theta \hat{\mathbf{y}}, \tag{17}$$

where $\hat{\mathbf{k}}_i = \sin \theta \hat{\mathbf{y}} + \cos \theta \hat{\mathbf{z}}$ and $\hat{\mathbf{k}}_r = \sin \theta \hat{\mathbf{y}} - \cos \theta \hat{\mathbf{z}}$. The interaction Poynting vector is

$$\langle \mathbf{S}_{\text{int}}(z < 0) \rangle = -c \epsilon_0 E_0^2 \sin \theta \cos(2kz \cos \theta) \hat{\mathbf{y}} = c \epsilon_0 E_0^2 \sin \theta [2 \sin^2(kz \cos \theta) - 1] \hat{\mathbf{y}}, \tag{18}$$

so the total energy flow is again given by eq. (15).

The existence of a nontrivial interaction term (18) in this simple example illustrates that some aspects of the description of energy flow via the Poynting vector are not very intuitive. For example, while the flow of energy in the incident or reflected beams, considered by themselves, has only a positive y -component, the direction of the interaction flow (18) oscillates in z with period $\lambda/(2 \cos \theta)$.

For possible clarification of the nature of the interaction flow, we next consider the reflection of beams with limited transverse extent.

2.2 Reflection of a Weakly Focused, Linearly Polarized Gaussian Optical Beam

2.2.1 Gaussian Optical Beams

We use so-called Gaussian beams of circular cross section to describe approximate wave solutions to Maxwell's equations that have limited transverse extent. For completeness, a derivation of the form of a linearly polarized Gaussian beam is given in the Appendix. In the **paraxial** approximation, such a beam that is polarized along the x -axis and propagating along the z -axis is described as

$$\begin{aligned}
E_x &\approx \frac{E_0 e^{-\rho^2/(1+z^2/z_0^2)}}{\sqrt{1+z^2/z_0^2}} e^{i\{kz[1+z_0\rho^2/k(z^2+z_0^2)]-\omega t-\tan^{-1}(z/z_0)\}}, \\
E_y &= 0,
\end{aligned} \tag{19}$$

$$E_z \approx -\frac{ix}{z_0} E_x \frac{e^{-i \tan^{-1} z/z_0}}{\sqrt{1+z^2/z_0^2}},$$

$$B_x = 0, \quad cB_y = E_x, \quad cB_z = -\frac{iy}{z_0} E_x \frac{e^{-i \tan^{-1} z/z_0}}{\sqrt{1+z^2/z_0^2}}, \tag{20}$$

where c is the speed of light in vacuum,

$$k = \frac{\omega}{c}, \quad \rho = \frac{\sqrt{x^2 + y^2}}{w_0} = \frac{r_{\perp}}{w_0}, \quad (21)$$

w_0 is the characteristic radius of the beam at its waist (focus), θ_0 is the diffraction angle and z_0 is the Rayleigh range, as shown in the figure below, which quantities are related by

$$\theta_0 = \frac{w_0}{z_0}, \quad z_0 = \frac{kw_0^2}{2} = \frac{2}{k\theta_0^2}. \quad (22)$$

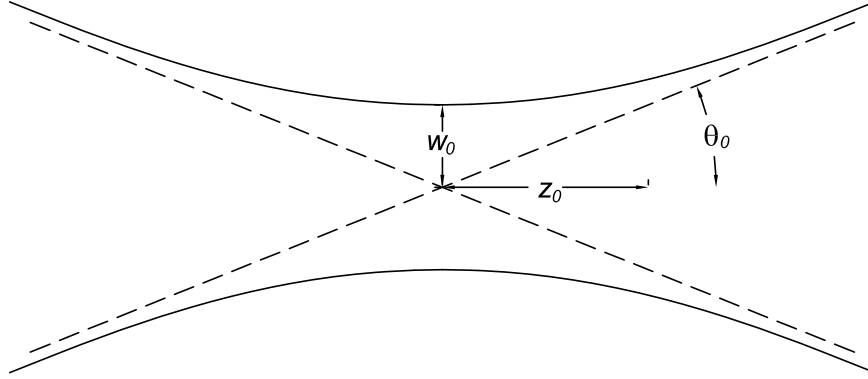

Near the focus ($\rho \lesssim 1, |z| \ll z_0$), the beam (19)-(20) can be approximated as the plane wave,¹

$$E_x = E_0 e^{-\rho^2} e^{i(kz - \omega t)}, \quad E_y = 0, \quad E_z = -\frac{ix}{z_0} E_x, \quad (23)$$

$$B_x = 0, \quad cB_y = E_x, \quad cB_z = -\frac{iy}{z_0} E_x, \quad (24)$$

which obeys $\nabla \cdot \mathbf{E} = 0 = \nabla \cdot \mathbf{B}$ recalling eq. (22). The equations $\nabla \times \mathbf{E} = -\partial \mathbf{B} / \partial t$ and $\nabla \times \mathbf{B} = \partial \mathbf{E} / \partial (c^2 t)$ are satisfied up to terms of order $\rho^2 \theta_0$. We are interested in transverse distances $\rho \lesssim 1$, so the approximation (23)-(24) is a good solution to Maxwell's equations provided $w_0 \ll z_0$, *i.e.*, $\theta_0 \ll 1$. This is the case in the present problem, where we wish to explore the behavior of very weakly focused optical beams.

The flow of energy in this beam near its waist is described by the (real) Poynting vector,

$$\mathbf{S} = c \epsilon_0 \text{Re} \mathbf{E} \times \text{Re} c \mathbf{B} \approx c \epsilon_0 E_0^2 e^{-2\rho^2} \left(\frac{r_{\perp}}{2z_0} \sin[2(kz - \omega t)] \hat{\mathbf{r}}_{\perp} + \cos^2(kz - \omega t) \hat{\mathbf{z}} \right). \quad (25)$$

The time-average flow of energy is, of course, only in the direction $\hat{\mathbf{z}}$ of propagation of the wave. In addition to the steady, time-average flow of energy (which obeys $\nabla \cdot \langle \mathbf{S} \rangle = 0$), there is an oscillatory transverse flow (and a corresponding oscillatory density u of energy stored in the electromagnetic field).²

¹The forms (23)-(24) could also be deduced quickly by first assuming E_y and B_x to be a plane wave with a Gaussian transverse modulation, and then enforcing conditions $\nabla \cdot \mathbf{E} = 0 = \nabla \cdot \mathbf{B}$ to determine E_z and B_z .

²Near its waist, a Gaussian beam is similar to a wave inside a conducting wave guide, which latter case also exhibits steady longitudinal, and oscillatory transverse, flow of energy [1].

2.2.2 Reflection by a Perfectly Conducting Planar Mirror

For simplicity, we again restrict our attention to the case that the x -polarization of the electric field is perpendicular to the plane of incidence, the y - z plane. The mirror is in the plane $z = 0$, and the beams exist in the half space $z < 0$.

The incident and reflected beams each have the Gaussian form (23)-(24), with respect to axes (x_i, y_i, z_i) and (x_r, y_r, z_r) , where the z_i - and z_r -axes are in the directions of propagation of the two beams. The transverse distance ρ_i in the incident beam can be written in laboratory coordinates using eq. (4),

$$\rho_i^2 = \frac{x_i^2 + y_i^2}{w_0^2} = \frac{x^2 + y^2 \cos^2 \theta - yz \sin 2\theta + z^2 \sin^2 \theta}{w_0^2}, \quad (26)$$

where θ is the angle between the axis of the incident beam and the z -axis, and we assume that axis of the incident beam passes through the origin. Then, combining eqs. (5) (23)-(26), the components of the incident beam in the laboratory frame are

$$E_{ix} = E_0 e^{-\rho_i^2} e^{i(ky \sin \theta + kz \cos \theta - \omega t)}, \quad (27)$$

$$E_{iy} = -i \frac{x \sin \theta}{z_0} E_{ix}, \quad (28)$$

$$E_{iz} = -i \frac{x \cos \theta}{z_0} E_{ix}, \quad (29)$$

$$B_{ix} = 0, \quad (30)$$

$$cB_{iy} = \left[\cos \theta - i \sin \theta \frac{y \cos \theta - z \sin \theta}{z_0} \right] E_{ix}, \quad (31)$$

$$cB_{iz} = - \left[\sin \theta + i \cos \theta \frac{y \cos \theta - z \sin \theta}{z_0} \right] E_{ix}. \quad (32)$$

Similarly, the transverse distance ρ_r in the reflected beam is

$$\rho_r^2 = \frac{x_r^2 + y_r^2}{w_0^2} = \frac{x^2 + y^2 \cos^2 \theta + yz \sin 2\theta + z^2 \sin^2 \theta}{w_0^2}, \quad (33)$$

in laboratory coordinates, and the field components of the reflected beam in the laboratory frame are

$$E_{rx} = E_{0r} e^{-\rho_r^2} e^{i(ky \sin \theta - kz \cos \theta - \omega t)}, \quad (34)$$

$$E_{ry} = -i \frac{x \sin \theta}{z_0} E_{rx}, \quad (35)$$

$$E_{rz} = i \frac{x \cos \theta}{z_0} E_{rx}, \quad (36)$$

$$B_{rx} = 0, \quad (37)$$

$$cB_{ry} = \left[-\cos \theta + i \sin \theta \frac{y \cos \theta + z \sin \theta}{z_0} \right] E_{rx}, \quad (38)$$

$$cB_{rz} = - \left[\sin \theta + i \cos \theta \frac{y \cos \theta + z \sin \theta}{z_0} \right] E_{rx}, \quad (39)$$

where we have assumed that the reflected beam also makes angle θ with respect to the z -axis, and that the axis of the reflected beam passes through the origin.

The boundary conditions at the perfectly conducting surface $z = 0$ are again satisfied by

$$E_{0r} = -E_0. \quad (40)$$

The time-average energy flow can now be described by the total Poynting vector,

$$\begin{aligned} \langle \mathbf{S} \rangle &= \frac{c \epsilon_0}{2} \text{Re}(\mathbf{E} \times c\mathbf{B}^*) = \frac{c \epsilon_0}{2} \text{Re}[(\mathbf{E}_i + \mathbf{E}_r) \times (c\mathbf{B}_i^* + c\mathbf{B}_r^*)] \\ &= \frac{c \epsilon_0}{2} \text{Re}(\mathbf{E}_i \times c\mathbf{B}_i^*) + \frac{c \epsilon_0}{2} \text{Re}(\mathbf{E}_r \times c\mathbf{B}_r^*) + \frac{c \epsilon_0}{2} \text{Re}[(\mathbf{E}_i \times c\mathbf{B}_r^*) + (\mathbf{E}_r \times c\mathbf{B}_i^*)] \\ &= \langle \mathbf{S}_i \rangle + \langle \mathbf{S}_r \rangle + \langle \mathbf{S}_{\text{int}} \rangle. \end{aligned} \quad (41)$$

Recalling eq. (25) we have that (for $-z_0 \lesssim z < 0$)

$$\langle \mathbf{S}_i \rangle \approx c \epsilon_0 \frac{E_0^2}{2} e^{-2\rho_i^2} \hat{\mathbf{k}}_i, \quad \langle \mathbf{S}_r \rangle \approx c \epsilon_0 \frac{E_0^2}{2} e^{-2\rho_r^2} \hat{\mathbf{k}}_r, \quad (42)$$

$$\langle \mathbf{S}_i \rangle + \langle \mathbf{S}_r \rangle \approx c \epsilon_0 \frac{E_0^2}{2} \left[\left(e^{-2\rho_i^2} + e^{-2\rho_r^2} \right) \sin \theta \hat{\mathbf{y}} + \left(e^{-2\rho_i^2} - e^{-2\rho_r^2} \right) \cos \theta \hat{\mathbf{z}} \right]. \quad (43)$$

Lines of the summed Poynting flux $\langle \mathbf{S}_i \rangle + \langle \mathbf{S}_r \rangle$ are sketched in the figure below, and are consistent with a naive expectation as to how the total energy flow should behave.

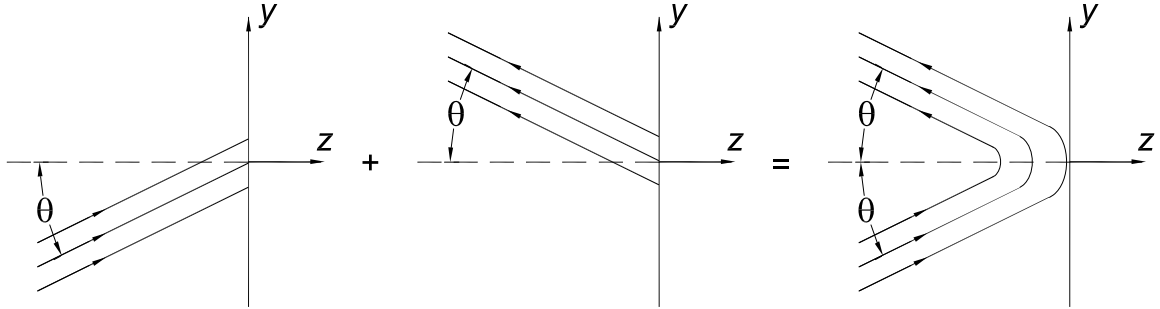

However, the total Poynting vector also includes the interaction term

$$\begin{aligned} \langle \mathbf{S}_{\text{int}}(-z_0 \lesssim z < 0) \rangle &\approx -c \epsilon_0 E_0^2 e^{-\rho_i^2 - \rho_r^2} \sin \theta \left[\left(\cos(2kz \cos \theta) + \frac{z \cos \theta}{z_0} \sin(2kz \cos \theta) \right) \hat{\mathbf{y}} \right. \\ &\quad \left. + \frac{y \cos \theta}{z_0} \sin(2kz \cos \theta) \hat{\mathbf{z}} \right], \end{aligned} \quad (44)$$

which obeys the condition of steady flow, $\langle \nabla \cdot \mathbf{S}_{\text{int}} \rangle = 0$ on neglect of small terms of order yz/z_0^2 . The interaction flow is significant only in the region of overlap of the incident and reflected beams, with flow lines roughly as sketched on the following page. While the flow of $\langle \mathbf{S}_i \rangle + \langle \mathbf{S}_r \rangle$ is counterclockwise in this example, the flow of $\langle \mathbf{S}_{\text{int}} \rangle$ is clockwise.

The area of a loop of the circulating interaction energy flow is of order λ^2 . It seems hard to give such loops a physical interpretation, especially in a quantum description, where a

photon of the field has characteristic size λ . Yet, Maxwell might have been pleased by the appearance of small loops of energy flow in a nominally simple example.

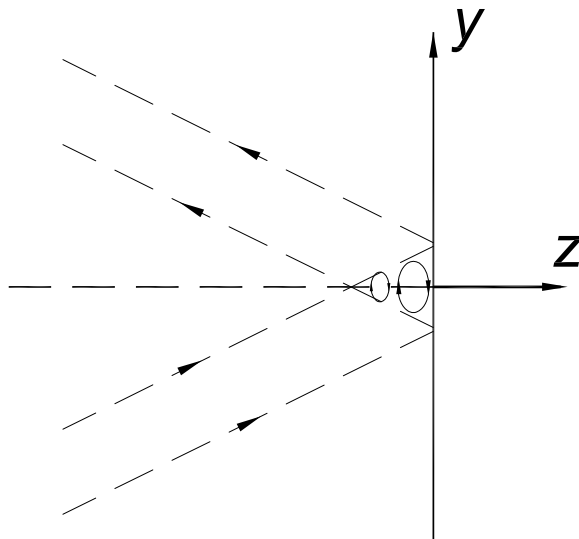

2.2.3 Angular Momentum

If the Gaussian beam were a pulse with a sharp wavefront, that wavefront would first encounter the mirror at negative values of y . The resulting initial pressure would exert a torque about the x -axis, and the mirror would begin to rotate in a counterclockwise sense, if free to turn about that axis. Similarly, if the pulse had a sharp trailing edge, this would last encounter the part of the mirror at positive values of y , imparting an angular momentum to the mirror that cancels that due to the leading edge of the pulse.

The initial and final angular momenta of the fields and of the mirror are zero. However, during the time that the beam is interacting with the mirror, the field angular momentum must be equal and opposite to that of the mirror, *i.e.*, clockwise. We see in the figure above that the flow of interaction energy in the loop closest to the mirror, which loop has the largest flow, is indeed clockwise, and qualitatively consistent with the total angular momentum of the system being zero.

The time-average field angular momentum $\langle \mathbf{L} \rangle_{\text{EM}}$ about the origin can be calculated as

$$\langle \mathbf{L} \rangle_{\text{EM}} = \int \mathbf{r} \times \frac{\langle \mathbf{S} \rangle}{c^2} d\text{Vol} = \int \mathbf{r} \times \left(\frac{\langle \mathbf{S} \rangle_i}{c^2} + \frac{\langle \mathbf{S} \rangle_r}{c^2} + \frac{\langle \mathbf{S} \rangle_{\text{int}}}{c^2} \right) d\text{Vol} = \langle \mathbf{L} \rangle_i + \langle \mathbf{L} \rangle_r + \langle \mathbf{L} \rangle_{\text{int}}, \quad (45)$$

where $\langle \mathbf{L} \rangle_i = 0 = \langle \mathbf{L} \rangle_r$, and the interaction angular momentum has only an x -component,

$$\begin{aligned} L_{\text{int},x} &= \int \frac{y \langle S \rangle_{\text{int},z} - z \langle S \rangle_{\text{int},y}}{c^2} d\text{Vol} \\ &\approx \frac{\epsilon_0}{c} E_0^2 \sin \theta \int e^{-\rho_i^2 - \rho_r^2} \left(z \cos(2kz \cos \theta) - \frac{(y^2 - z^2) \cos \theta}{z_0} \sin(2kz \cos \theta) \right) d\text{Vol} \\ &\approx \frac{\epsilon_0}{c} E_0^2 \sin \theta \int e^{-\rho_i^2 - \rho_r^2} z \cos(2kz \cos \theta) d\text{Vol}, \end{aligned} \quad (46)$$

which could be evaluated numerically.

A Appendix: Gaussian Beams

We review one derivation of a linearly polarized Gaussian beam, say with $E_x = f(r, z)e^{i(kz - \omega t)}$ that is cylindrically symmetric with angular frequency ω and wave number $k = \omega/c$ and propagating along the z axis in vacuum. Of course, the electric field must satisfy the free-space Maxwell equation $\nabla \cdot \mathbf{E} = 0$. If $f(r, z)$ is not constant and $E_y = 0$, then we must have nonzero E_z . That is, the desired electric field actually has more than one vector component.

To deduce all components of the electric and magnetic fields of a Gaussian beam from a single scalar wave function, we follow the suggestion of Davis [2] and seek solutions for a vector potential \mathbf{A} that has only a single Cartesian component (such that $(\nabla^2 \mathbf{A})_j = \nabla^2 A_j$ [3]). We work in the Lorenz gauge (and SI units), so that the electric scalar potential Φ is related to the vector potential \mathbf{A} by

$$\nabla \cdot \mathbf{A} = -\frac{1}{c^2} \frac{\partial \Phi}{\partial t} = i \frac{\omega}{c^2} \Phi = i \frac{k^2}{\omega} \Phi. \quad (47)$$

The vector potential can therefore have a nonzero divergence, which permits solutions having only a single component.

Of course, the electric and magnetic fields can be deduced from the potentials via

$$\mathbf{E} = -\nabla \Phi - \frac{\partial \mathbf{A}}{\partial t} = i \frac{\omega}{k^2} \nabla (\nabla \cdot \mathbf{A}) + i \omega \mathbf{A}, \quad (48)$$

using the Lorenz condition (47), and

$$\mathbf{B} = \nabla \times \mathbf{A}. \quad (49)$$

The vector potential satisfies the free-space (Helmholtz) wave equation,

$$\nabla^2 \mathbf{A} - \frac{1}{c^2} \frac{\partial^2 \mathbf{A}}{\partial t^2} = (\nabla^2 + k^2) \mathbf{A} = 0. \quad (50)$$

We seek a solution in which the vector potential is described by a single Cartesian component A_j that propagates in the $+z$ direction with the form

$$A_j(\mathbf{r}) = \psi(\mathbf{r})e^{i(kz - \omega t)}. \quad (51)$$

Inserting trial solution (51) into the wave equation (50) we find that

$$\nabla^2 \psi + 2ik \frac{\partial \psi}{\partial z} = 0. \quad (52)$$

In the usual analysis, one now assumes that the beam is cylindrically symmetric about the z axis and can be described in terms of three geometric parameters the diffraction angle θ_0 , the waist w_0 , and the depth of focus (Rayleigh range) z_0 , which are related by

$$\theta_0 = \frac{w_0}{z_0} = \frac{2}{kw_0}, \quad \text{and} \quad z_0 = \frac{kw_0^2}{2} = \frac{2}{k\theta_0^2}. \quad (53)$$

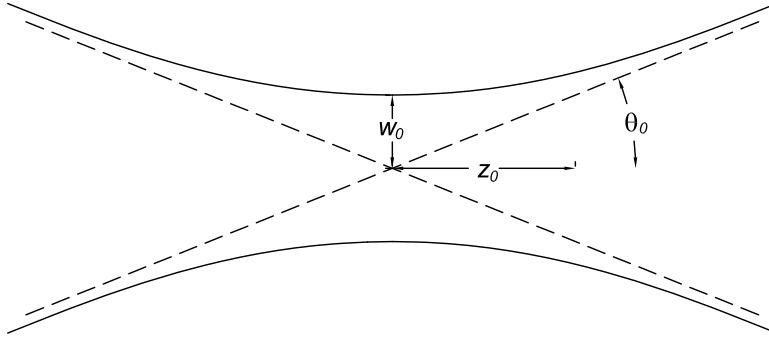

We now convert to the scaled coordinates

$$\xi = \frac{x}{w_0}, \quad v = \frac{y}{w_0}, \quad \rho^2 = \xi^2 + v^2, \quad \text{and} \quad \varsigma = \frac{z}{z_0}. \quad (54)$$

Changing variables and noting relations (53), the wave equation (52) takes the form

$$\frac{\partial^2 \psi}{\partial \xi^2} + \frac{\partial^2 \psi}{\partial v^2} + \theta_0^2 \frac{\partial^2 \psi}{\partial \varsigma^2} + 4i \frac{\partial \psi}{\partial \varsigma} = 0. \quad (55)$$

The paraxial approximation is that the term in the small quantity θ_0^2 is neglected, and the resulting paraxial wave equation is

$$\frac{\partial^2 \psi}{\partial \xi^2} + \frac{\partial^2 \psi}{\partial v^2} + 4i \frac{\partial \psi}{\partial \varsigma} \approx 0. \quad (56)$$

An “educated guess” is that the transverse behavior of the wave function ψ has a Gaussian form, but with a width that varies with z . Also, the amplitude of the wave far from its waist should vary as $1/z$. In the scaled coordinates ρ and ς a trial solution is

$$\psi = h(\varsigma) e^{-f(\varsigma) \rho^2}, \quad (57)$$

where the possibly complex functions f and h are defined to obey $f(0) = 1 = h(0)$. Since the transverse coordinate ξ and v are scaled by the waist w_0 , we see that $Re(f) = w_0^2/w^2(\varsigma)$ where $w(\varsigma)$ is the beam width at position ς . From the geometric parameters (54) we see $w(\varsigma) \approx \theta_0 z = w_0 \varsigma$ for large ς . Hence, we expect that $Re(f) \approx 1/\varsigma^2$ for large ς . Also, we expect the amplitude h to obey $|h| \approx 1/\varsigma$ for large ς .

Plugging the trial solution (57) into the paraxial wave equation (56) we find that

$$-fh + ih' + \rho^2 h(f^2 - if') \approx 0. \quad (58)$$

We see that for eq. (58) to be true at all values of ρ implies that

$$\frac{f'}{f^2} = -i, \quad \text{and} \quad \frac{h'}{fh} = -i. \quad (59)$$

Thus, $f = h$ is a solution, despite the different physical origin of these two functions as the transverse width and amplitude of the wave. We integrate the first of eq. (59) to obtain

$$\frac{1}{f} = C + i\varsigma. \quad (60)$$

Our definition $f(0) = 1$ determines that $C = 1$. That is,

$$f = \frac{1}{1+i\zeta} = \frac{1-i\zeta}{1+\zeta^2} = \frac{e^{-i \tan^{-1} \zeta}}{\sqrt{1+\zeta^2}}. \quad (61)$$

Note that $Re(f) = 1/(1+\zeta^2) = w_{0j}^2/w_j^2(\zeta)$, while $|f| = 1/\sqrt{1+\zeta^2}$, so that $f = h$ is consistent with the asymptotic expectations discussed above. The longitudinal dependence of the width of the Gaussian beam is now seen to be

$$w(\zeta) = w_0 \sqrt{1+\zeta^2}. \quad (62)$$

The lowest-order wave function is

$$\psi_0 = f e^{-f\rho^2} = \frac{e^{-i \tan^{-1} \zeta}}{\sqrt{1+\zeta^2}} e^{-\rho^2/(1+\zeta^2)} e^{i\zeta\rho^2/(1+\zeta^2)}. \quad (63)$$

The factor $e^{-i \tan^{-1} \zeta}$ in ψ_0 is the so-called **Gouy phase shift** [4], which changes from 0 to $\pi/2$ as z varies from 0 to ∞ , with the most rapid change near the z_0 . For large z the phase factor $e^{i\zeta\rho^2/(1+\zeta^2)}$ can be written as $e^{i(z_0/z)(r_\perp^2/w_0^2)} \approx e^{ikr_\perp^2/(2z)}$, recalling eq. (53). When this is combined with the traveling wave factor $e^{i(kz-\omega t)}$ we have

$$e^{i[kz(1+r_\perp^2/2z^2)-\omega t]} \approx e^{i(kr-\omega t)}, \quad (64)$$

where $r = \sqrt{z^2 + r_\perp^2}$. Thus, the wave function ψ_0 is a modulated spherical wave for large z , but is a modulated plane wave near its waist.

To obtain the electric and magnetic fields of a Gaussian beam that is polarized in the y direction we take the vector potential to be

$$A_x = \frac{E_0}{i\omega} \psi_0 e^{i(kz-\omega t)} = \frac{E_0}{i\omega} f e^{-f\rho^2} e^{i(kz-\omega t)}, \quad A_y = 0, \quad A_z = 0. \quad (65)$$

Then,

$$\nabla \cdot \mathbf{A} = -\frac{2fx}{w_0^2} A_x. \quad (66)$$

and the electric field follows from eq. (48) as

$$E_x \approx E_0 f e^{-f\rho^2} e^{i(kz-\omega t)}, \quad E_y \approx 0, \quad E_z \approx -i \frac{x}{z_0} f E_x, \quad (67)$$

where we neglect terms of order $1/z_0^2$. Similarly, the magnetic field follows from eq. (49) as

$$B_x = 0, \quad cB_y = E_x, \quad cB_z = -i \frac{y}{z_0} f E_x. \quad (68)$$

The time-average flow of energy in the Gaussian beam (67)-(68) is described by the Poynting vector

$$\begin{aligned} \langle \mathbf{S} \rangle &= \frac{c\epsilon_0}{2} Re(\mathbf{E} \times \mathbf{B}^*) \approx \frac{c\epsilon_0}{2} E_0^2 |f|^2 e^{-2Re f \rho^2} \left(\frac{\zeta}{z_0(1+\zeta^2)} \mathbf{r}_\perp + \hat{\mathbf{z}} \right) \\ &= \frac{c\epsilon_0}{2} \frac{E_0^2}{(1+z^2/z_0^2)} e^{-2r_\perp^2/\theta_0^2(z^2+z_0^2)} \left(\frac{r_\perp z}{z^2+z_0^2} \hat{\mathbf{r}}_\perp + \hat{\mathbf{z}} \right). \end{aligned} \quad (69)$$

Far from the waist, where $|z| \gg z_0$, the Poynting vector is

$$\langle \mathbf{S}(|z| \gg z_0) \rangle \approx \frac{c \epsilon_0}{2} E_0^2 \frac{z_0^2 e^{-2r_\perp^2/\theta_0^2 z^2}}{z^2} \left(\frac{r_\perp}{z} \hat{\mathbf{r}}_\perp + \hat{\mathbf{z}} \right) \approx \frac{c \epsilon_0}{2} E_0^2 \frac{z_0^2 e^{-2\theta^2/\theta_0^2}}{r^2} \hat{\mathbf{r}}, \quad (70)$$

where $\theta \approx r_\perp/z$ is the polar angle with respect to the z -axis. Close from the waist, where $|z| \ll z_0$, the Poynting vector is

$$\langle \mathbf{S}(|z| \ll z_0) \rangle \approx \frac{c \epsilon_0}{2} E_0^2 e^{-2r_\perp^2/\theta_0^2 z_0^2} \hat{\mathbf{z}} \approx \frac{c \epsilon_0}{2} E_0^2 e^{-2r_\perp^2/w_0^2} \hat{\mathbf{z}}. \quad (71)$$

Lines of the Poynting vector (69) are sketched below. All the energy within a circle of radius w_0 in the plane $z = 0$ appears within a cone of half angle θ_0 at large z .

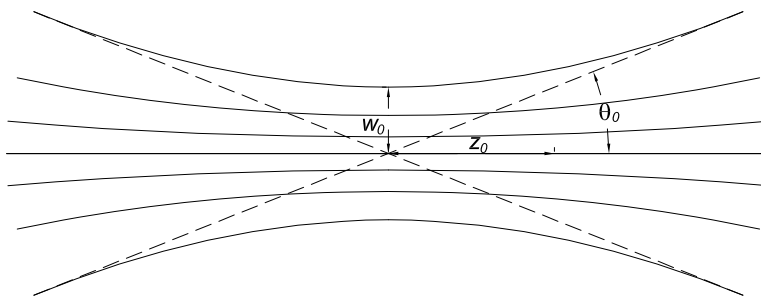

The fields E_x and E_z , *i.e.*, the real parts of eqs. (67), are shown in Figs. 1 and 2.

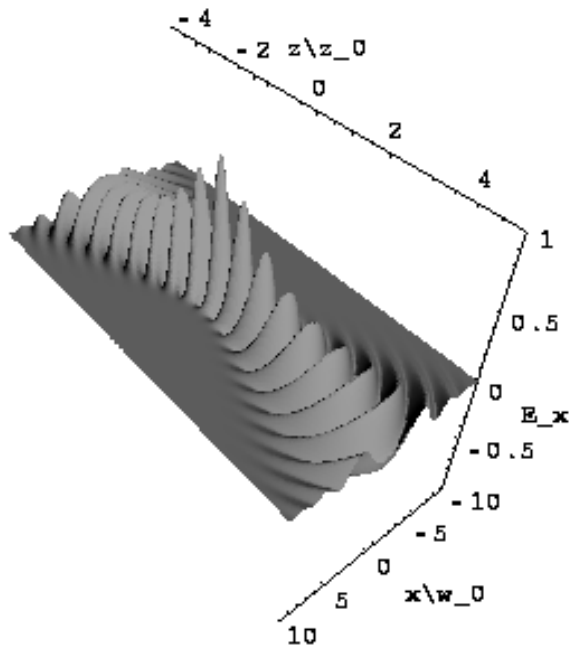

Figure 1: The electric field $E_x(x, 0, z)$ of a linearly polarized Gaussian beam with diffraction angle $\theta_0 = 0.45$, according to eq. (67).

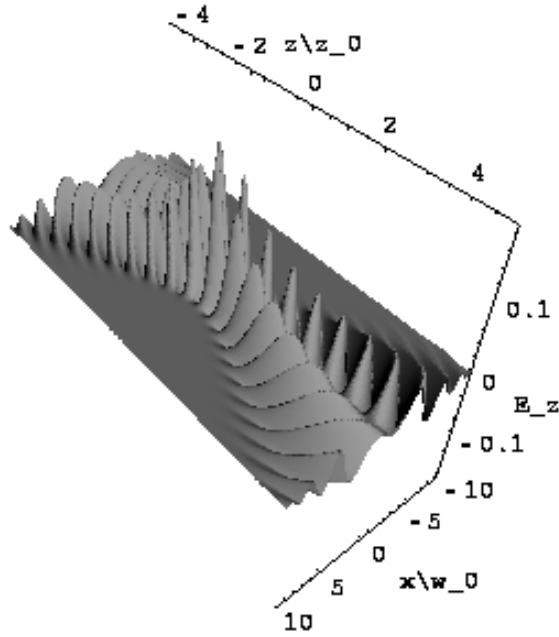

Figure 2: The electric field $E_z(x, 0, z)$ of a linearly polarized Gaussian beam with diffraction angle $\theta_0 = 0.45$, according to eq. (67).

References

- [1] M. Moriconi and K.T. McDonald, *Energy Flow in a Waveguide below Cutoff* (May 20, 2009), <http://puhep1.princeton.edu/~mcdonald/examples/cutoff.pdf>
- [2] L.W. Davis, *Theory of electromagnetic beams*, Phys. Rev. A **19**, 1177-1179 (1979), http://puhep1.princeton.edu/~mcdonald/examples/optics/davis_pra_19_1177_79.pdf
- [3] P.M. Morse and H. Feshbach, *Methods of Theoretical Physics*, Part I (McGraw-Hill, New York, 1953), pp. 115-116.
- [4] G. Gouy, *Sur une propreite nouvelle des ondes lumineuses*, Compt. Rendue Acad. Sci. (Paris) **110**, 1251 (1890); *Sur la propagation anomele des ondes*, *ibid.* **111**, 33 (1890), http://puhep1.princeton.edu/~mcdonald/examples/optics/gouy_cr_110_1251_90.pdf
http://puhep1.princeton.edu/~mcdonald/examples/optics/gouy_cr_111_33_90.pdf