

Ph 406: Elementary Particle Physics

Problem Set 2

K.T. McDonald
 kirkmcd@princeton.edu
 Princeton University

Due Monday, September 29, 2014 (updated September 20, 2016)

1. The reactions $\pi^\pm p \rightarrow \mu^+ \mu^-$ are thought to proceed via single-photon exchange according to the so-called Drell-Yan diagram. Use the quark model to predict the cross-section ratio

$$\frac{\sigma_{\pi^- p \rightarrow \mu^+ \mu^-}}{\sigma_{\pi^+ p \rightarrow \mu^+ \mu^-}}.$$

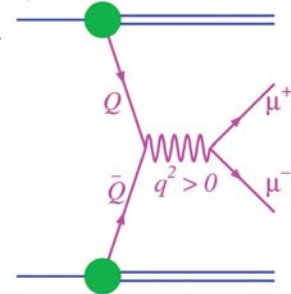

2. Discuss the motion of an electron of charge $-e$ and rest mass m that is at rest on average inside a plane electromagnetic wave which propagates in the $+z$ direction of a rectangular coordinate system. Suppose the wave is linearly polarized along \mathbf{x} ,

$$\mathbf{E}_{\text{wave}} = \hat{\mathbf{x}}E_0 \cos(kz - \omega t), \quad \mathbf{B}_{\text{wave}} = \hat{\mathbf{y}}E_0 \cos(kz - \omega t), \quad (1)$$

where $\omega = kc$ is the angular frequency of the wave, $k = 2\pi/\lambda$ is the wave number, c is the speed of light in vacuum, and $\hat{\mathbf{x}}$ is a unit vector in the x direction.

Consider only weak fields, for which the dimensionless field-strength parameter $\eta \ll 1$, where

$$\eta = \frac{eE_0}{m\omega c}. \quad (2)$$

First, ignore the longitudinal motion, and deduce the transverse motion, expressing its amplitude in terms of η and λ . Then, in a “macroscopic” view which averages over the “microscopic” motion, the time-average total energy of the electron can be regarded as $\overline{m}c^2$, where $\overline{m} > m$ is the effective mass of the electron (considered as a **quasiparticle** in the quantum view). That is, the “background” electromagnetic field has “given” mass to the electron beyond that in zero field.

This is an electromagnetic version of the Higgs (Kibble) mechanism.¹

Also, deduce the form of the longitudinal motion for $\eta \ll 1$.

Not for credit: Where does the energy and (transverse) momentum of the electron come from?

¹For an insightful discussion by Kibble that elaborates on the present problem, see [1].

3. The Weizsäcker-Williams Approximation

Following an earlier discussion by Fermi [2], Weizsäcker [3] and Williams [4] noted that the electromagnetic fields of an electron in uniform relativistic motion are predominantly transverse, with $\mathbf{E} \approx \mathbf{B}$ (in Gaussian units). This is very much like the fields of a plane wave, so one is led to regard a fast electron as carrying with it a cloud of virtual photons that it can shed (radiate) if perturbed.

The key features of the frequency spectrum of the fields can be estimated as follows. To an observer at rest at distance b from the electron's trajectory, the peak electric field is $E = \gamma e/b^2$, and the field remains above half this strength for time $b/\gamma c$, so the frequency spectrum of this pulse extends up to $\omega_{\max} \approx \gamma c/b$. The total energy of the pulse (relevant to this observer) is $U \approx E^2 \text{Vol} \approx \gamma^2 e^2/b^4 \cdot b^2 \cdot b/\gamma \approx \gamma e^2/b$.

If the electron radiates all of this energy, the energy spectrum would be

$$\frac{dU(\omega)}{d\omega} \approx \frac{U}{\omega_{\max}} \approx \frac{e^2}{c}. \quad (3)$$

This result does not depend on the choice of impact parameter b , and is indeed of general validity (to within a factor of $\ln \gamma$). The number of photons n_ω of frequency ω is thus

$$dn_\omega = \frac{dU(\omega)}{\hbar\omega} \approx \frac{e^2}{\hbar c} \frac{d\omega}{\omega} = \alpha \frac{d\omega}{\omega}, \quad (4)$$

where $\alpha = e^2/\hbar c \approx 1/137$ is the fine structure constant.

The quick approximation (3)-(4) is not accurate at high frequencies. In general, additional physical arguments are needed to identify the maximum frequency of its validity, called the characteristic or critical frequency ω_C , or equivalently, the minimum relevant impact parameter b_{\min} . A more detailed evaluation of the high-frequency tail of the virtual photon spectrum shows it to be [2, 3, 4, 5]

$$dn_\omega \approx \alpha \frac{d\omega}{\omega} e^{-2\omega b_{\min}/\gamma c} \quad (\text{high frequency}). \quad (5)$$

From this, we see the general relation between the critical frequency and the minimum impact parameter is

$$\omega_C \approx \gamma \frac{c}{b_{\min}}, \quad b_{\min} \approx \gamma \lambda_C. \quad (6)$$

The characteristic angular spread θ_C of the radiation pattern near the critical frequency can be estimated from eq. (6) by noting that the radiation is much like that of a beam of light with waist b_{\min} . Then, from the laws of diffraction we conclude that

$$\theta_C \approx \frac{\lambda_C}{b_{\min}} \approx \frac{1}{\gamma}. \quad (7)$$

This behavior is also expected in that a ray of light emitted in the electron's rest frame at 90° appears at angle $1/\gamma$ to the laboratory direction of the electron.

The Formation Length

To complete an application of the Weizsäcker-Williams method, we must also know over what interval the virtual photon cloud is shaken off the electron to become the radiation detected in the laboratory. Intense (and hence, physically interesting) radiation processes are those in which the entire cloud of virtual photons is emitted as rapidly as possible. This is usefully described by the so-called formation time t_0 and the corresponding formation length $L_0 = vt_0$ where $v \approx c$ is the velocity of the relativistic electron.

The formation length (time) is the distance (time) the electron travels while a radiated wave advances one wavelength λ ahead of the projection of the electron's motion onto the direction of observation. The wave takes on the character of radiation that is no longer tied to its source only after the formation time has elapsed. That is,

$$\lambda = ct_0 - vt_0 \cos \theta \approx L_0(1 - \beta \cos \theta) \approx L_0 \left(\frac{1}{2\gamma^2} + \frac{\theta^2}{2} \right), \quad (8)$$

for radiation observed at angle θ to the electron's trajectory. Thus, the formation length is given by

$$L_0 \approx \frac{2\lambda}{\theta^2 + 1/\gamma^2} \quad (9)$$

If the frequency of the radiation is near the critical frequency (6), then the radiated intensity is significant only for $\theta \lesssim \theta_C \approx 1/\gamma$, and the formation length is

$$L_0 \approx \gamma^2 \lambda \quad (\lambda \approx \lambda_C). \quad (10)$$

A good discussion of the formation length in both classical and quantum contexts has been given in ref. [6].

Summary of the Method

A relativistic electron carries with it a virtual photon spectrum of α photons per unit frequency interval. When radiation occurs, for whatever reason, the observed frequency spectrum will closely follow this virtual spectrum. In cases where the driving force for the radiation extends over many formation lengths, the spectrum of radiated photons per unit path length for intense processes is given by expressions (4)-(5), which describe the radiation emitted over one formation length, divided by the formation length (9):

$$\frac{dn_\omega}{dl} \approx \frac{\alpha}{L_0(\omega)} \frac{d\omega}{\omega} \times \begin{cases} 1 & (\omega < \omega_C), \\ e^{-\omega/\omega_C} & (\omega \geq \omega_C). \end{cases} \quad (11)$$

Synchrotron radiation, undulator radiation, transition radiation, and Čerenkov radiation are examples of processes which can be described within the context of classical electromagnetism, but for which the Weizsäcker-Williams approximation is also suitable. Čerenkov radiation and transition radiation are often thought of as rather weak processes, but the Weizsäcker-Williams viewpoint indicates that they are actually as

intense as is possible for radiation by a single charge, in the sense that the entire virtual photon cloud is liberated over a formation length.

In this problem, we emphasize a simplified version of the Weizsäcker-Williams method with the goal of illustrating the main qualitative features of synchrotron radiation.²

The Problem: Synchrotron Radiation

Synchrotron radiation arises when a charge, usually an electron, is deflected by a magnetic field.³ For a large enough region of uniform magnetic field, the electron's trajectory would be a complete circle. However, synchrotron radiation as considered here occurs whenever the magnetic-field region is longer than a formation length.⁴

Consider an electron of Lorentz factor $\gamma \gg 1$ that moves in a circle of radius R . First, deduce the characteristic/critical frequency ω_C of the radiation by estimating the time width of a pulse of radiation detected by a fixed observer as the “searchlight” beam of synchrotron radiation sweeps past him/her. Then, reconsider the meaning of the formation length L_0 noting that the electron moves on a circle but photons move on a chord to find a cubic relation between the wavelength λ and the “formation angle” $\theta_0 = L_0/R$. Consider separately the limiting cases $\lambda \gg \lambda_C$ and $\lambda \ll \lambda_C$, and estimate the frequency spectra dn_ω/dl for these cases, as well as the energy spectra $dU(\omega)/dl$, where l is path length along the electron's trajectory. Compare the integral over frequency of your energy spectrum with the Larmor formula (*using the Hint at the end of prob. 5*).

4. A betatron⁵ is a circular device of radius R designed to accelerate electrons (charge e , mass m) via a changing magnetic flux $\dot{\Phi} = \pi R^2 \dot{B}_{\text{ave}}$ through the circle. Side views of early versions are shown below.

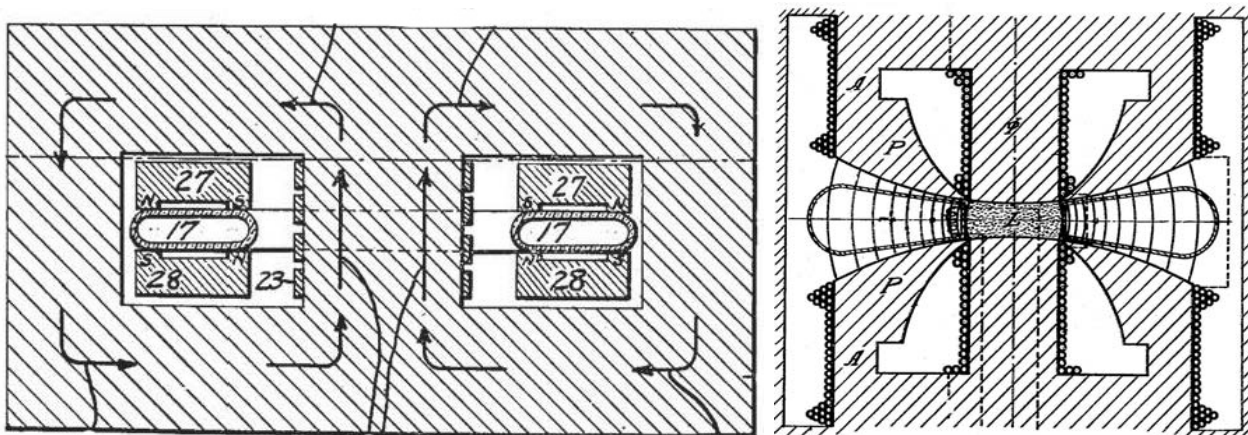

Deduce the relation between the magnetic field B at radius R and the magnetic field B_{ave} averaged over the area of the circle needed for a betatron to function. Also deduce

²A more detailed analysis can reproduce the complete forms of the classical radiation, as has been demonstrated for synchrotron radiation in [8].

³Synchrotron radiation is sometimes called **magnetic Bremsstrahlung**. See, for example, sec. 74 of [7].

⁴The radiation observed when the magnetic field extends for less than a formation length has been discussed in [8, 9, 10].

⁵The name **betatron** was given by Kerst [14] to the circular induction accelerator after its first successful demonstration [15, 16], which followed a long conceptual history [17, 18, 19, 20, 21, 22, 23].

the maximum energy \mathcal{E} to which an electron could be accelerated by a betatron in terms of B , $\dot{B}_{\text{ave}} \equiv B/\tau$, R and the QED critical field strength B_{crit} of prob. 4, set. 1.

Hints: The electrons in this problem are relativistic, so it is useful to introduce the factor $\gamma = \mathcal{E}/mc^2$ where c is the speed of light. Recall that Newton's second law has the same form for nonrelativistic and relativistic electrons except that in the latter case the effective mass is γm . Recall also that for circular motion the rest frame acceleration is γ^2 times that in the lab frame, and that the power radiated by an accelerated charge is a relativistic invariant (in that both energy and time are time-components of 4-vectors; for elaborations, see, http://physics.princeton.edu/~mcdonald/examples/moving_far.pdf).

For a problem on the stability of orbits in a betatron, see

http://physics.princeton.edu/~mcdonald/examples/betatron_osc.pdf.

This example is an introduction to the issue of stability of beams in particle accelerators.

5. A magnetic monopole of magnetic charge g , mass m and velocity $\beta = v/c$ passes through a material with electron density N/cm^3 and unit relative permeability. Estimate the energy loss, dE/dx , of the monopole assuming $\beta \approx 1$. *Hint: What is the Lorentz force on a magnetic monopole?*

Compare your result to that for particles of electrical charge e supposing that the monopole satisfies Dirac's quantum condition $eg = \hbar c/2$, where $-e$ is the charge on an electron [28].⁶

For magnetic monopoles with $\beta \approx 10^{-3}$, as might be consistent with extragalactic origin, your result for dE/dx should be modified. Consider energy loss in a metal plate of resistivity ρ due to Joule heating by the Eddy currents induced by the changing magnetic flux as the monopole passes through with normal incidence. *You may assume that β remains constant. An example of an Eddy-current calculation is at*

<http://physics.princeton.edu/~mcdonald/examples/pennies.pdf>

Note that the macroscopic concept of Joule heating does not apply for arbitrarily small length scales.

There exists an unresolved puzzle that if both electric charges and magnetic charges (monopoles) exist then energy may not be conserved,

<http://physics.princeton.edu/~mcdonald/examples/comay.pdf>.

⁶See, for example, sec. 6.12 of [5].

References

- [1] T.W.B. Kibble, *Mutual Refraction of Electrons and Photons*, Phys. Rev. **150**, 1060 (1966), http://physics.princeton.edu/~mcdonald/examples/QED/kibble_pr_150_1060_66.pdf
- [2] E. Fermi, *Über die Theorie des Stoßes zwischen Atomen und elektrisch geladenen Teilchen*, Z. Phys. **29**, 315-327 (1924),
http://physics.princeton.edu/~mcdonald/examples/EM/fermi_zp_29_315_24.pdf
- [3] C.F. von Weizsäcker, *Ausstrahlung bei Stößen sehr schneller Elektronen*, Z. Phys. **88**, 612-625 (1934), http://physics.princeton.edu/~mcdonald/examples/EM/weizsacker_zp_88_612_34.pdf
- [4] E.J. Williams, *Correlation of Certain Collision Problems with Radiation Theory*, Kgl. Danske Videnskab. Selskab Mat.-Fys. Medd. **13**, No. 4 (1935),
http://physics.princeton.edu/~mcdonald/examples/QED/williams_dkdvsmfm_13_4_1_35.pdf
- [5] J.D. Jackson, *Classical Electrodynamics*, 3rd ed., (Wiley, New York, 1999).
- [6] S. Klein, *Suppression of bremsstrahlung and pair production due to environmental factors*, Rev. Mod. Phys. **75**, 1501-1538 (1999),
http://physics.princeton.edu/~mcdonald/examples/accel/klein_rmp_75_1501_99.pdf
- [7] L.D. Landau and E.M. Lifshitz, *The Classical Theory of Fields*, 4th ed. (Pergamon, 1975).
- [8] R. Lieu and W.I. Axford, *Synchrotron Radiation: an Inverse Compton Effect*, Ap. J. **416**, 700-706 (1993),
http://physics.princeton.edu/~mcdonald/examples/accel/lieu_apj_416_700_93.pdf
Quantum-Limited Synchrotron Radiation in Inhomogeneous Magnetic Fields, *ibid.* **447**, 302-304 (1995),
http://physics.princeton.edu/~mcdonald/examples/accel/lieu_apj_447_302_95.pdf
- [9] R. Coisson, *On Synchrotron Radiation in Short Magnets*, Opt. Comm. **22**, 135 (1977),
http://physics.princeton.edu/~mcdonald/examples/accel/coisson_oc_22_135_77.pdf
- [10] V.G. Bagrov *et al.*, *Radiation of Relativistic Electrons Moving in an Arc of a Circle*, Phys. Rev. D **28**, 2464 (1983),
http://physics.princeton.edu/~mcdonald/examples/accel/bagrov_prd_28_2464_83.pdf
- [11] See, for example, chap. 4 of L. Mandel and E. Wolf, *Optical Coherence and Quantum Optics* (Cambridge University Press, Cambridge, 1995).
- [12] G. Gouy, *Sur une propriété nouvelle des ondes lumineuse*, Compt. Rendue (Paris) **110**, 1251-1253 (1890), http://physics.princeton.edu/~mcdonald/examples/optics/gouy_cr_110_1251_90.pdf
Sur la propagation anomele des ondes, *ibid.* **111**, 33 (1890),
http://physics.princeton.edu/~mcdonald/examples/optics/gouy_cr_111_33_90.pdf
Ann. de Chim. et Phys. **24**, 145-213 (1891); see also sec. 17.4 of [13].
- [13] A.E. Siegman, *Lasers* (University Science Books, Mill Valley, CA, 1986).

- [14] D.W. Kerst, *A 20-Million Electron-Volt Betatron or Induction Accelerator*, Rev. Sci. Instr. **13**, 387 (1942), http://physics.princeton.edu/~mcdonald/examples/accel/kerst_rsi_13_387_42.pdf
- [15] D.W. Kerst, *Acceleration of Electrons by Magnetic Induction*, Phys. Rev. **58**, 841 (1940), http://physics.princeton.edu/~mcdonald/examples/accel/kerst_pr_58_841_40.pdf
- [16] D.W. Kerst, *The Acceleration of Electrons by Magnetic Induction*, Phys. Rev. **60**, 47 (1941), http://physics.princeton.edu/~mcdonald/examples/accel/kerst_pr_60_47_41.pdf
- [17] J. Slepian, *X-Ray Tube*, US Patent 1,645,304 (1922), http://physics.princeton.edu/~mcdonald/examples/accel/slepian_1645304.pdf
- [18] G. Breit and M.A. Tuve, *Carnegie Institution Year Book* **27**, 209 (1927).
- [19] E.T.S. Walton, *The Production of High Speed Electrons by Indirect Means*, Proc. Camb. Phil. Soc. **25**, 469 (1929), http://physics.princeton.edu/~mcdonald/examples/accel/walton_pcps_25_469_29.pdf
- [20] J.D. Cockcroft, *The Cyclotron and Betatron*, J. Sci. Instr. **21**, 189 (1944), http://physics.princeton.edu/~mcdonald/examples/accel/cockroft_jsi_21_189_44.pdf
- [21] R. Wideroe, *Über ein neues Prinzip zur Herstellung hoher Spannungen*, Ark. Electr. **20**, 387 (1928), http://physics.princeton.edu/~mcdonald/examples/accel/wideroe_ae_21_387_28.pdf
- [22] W.W. Jassinsky, *Beschleunigung der Elektronen im elektromagnetischen Wechselstromfeld*, Ark. Electr. **30**, 590 (1936), http://physics.princeton.edu/~mcdonald/examples/accel/jassinsky_ae_30_590_36.pdf
- [23] M. Steenbeck, *Device for Producing Electron Rays of High Energy*, US Patent 2,103,303 (1936), http://physics.princeton.edu/~mcdonald/examples/patents/steenbeck_2103303.pdf
- [24] D.W. Kerst and R. Serber, *Electron Orbits in the Induction Accelerator*, Phys. Rev. **60**, 53 (1941), http://physics.princeton.edu/~mcdonald/examples/accel/kerst_pr_60_53_41.pdf
- [25] N. Christofilos, *Focusing System for Ions and Electrons*, US Patent 2,736,799 (filed 1950), http://physics.princeton.edu/~mcdonald/examples/accel/christofilos_2736799_50.pdf
- [26] E.D. Courant, M.S. Livingston and H.S. Snyder, *The Strong-Focusing Synchrotron—A New High Energy Accelerator*, Phys. Rev. **88**, 1190 (1952), http://physics.princeton.edu/~mcdonald/examples/accel/courant_pr_88_1190_52.pdf
- [27] E.D. Courant and H.S. Snyder, *Theory of the Alternating-Gradient Synchrotron*, Ann. Phys. **3**, 1 (1958), http://physics.princeton.edu/~mcdonald/examples/accel/courant_ap_3_1_58.pdf
- [28] P.A.M. Dirac, *Quantised Singularities in the Electromagnetic Field*, Proc. Phys. Soc. London A **133**, 60 (1931), http://physics.princeton.edu/~mcdonald/examples/QED/dirac_prsla_133_60_31.pdf

Solutions

1. The π^- is a $\bar{u}d$ diquark state, while the π^+ is a $u\bar{d}$ state.

The Drell-Yan amplitude is proportional to $Q_{\bar{q}}$ times the number of quarks in the proton (uud) that the \bar{q} could annihilate with. Hence the amplitude for $\pi^- p \rightarrow \mu^+ \mu^-$ is proportional to $(2/3) \cdot 2$, while that for $\pi^+ p \rightarrow \mu^+ \mu^-$ is proportional to $(1/3) \cdot 1$. The cross section is proportional to the square of the amplitude, so we predict that

$$\frac{\sigma_{\pi^- p \rightarrow \mu^+ \mu^-}}{\sigma_{\pi^+ p \rightarrow \mu^+ \mu^-}} = 16.$$

2. Transverse Motion of the Electron in a Weak Wave

A free electron of mass m oscillates in this field such that its average position is at the origin. This simple statement hides the subtlety that our frame of reference is not the lab frame of an electron that is initially at rest, but which is overtaken by a wave. If the velocity of the oscillating electron is small, we can ignore the $\mathbf{v}/c \times \mathbf{B}$ force and take the motion to be entirely in the plane $z = 0$. Then, (also ignoring radiation damping) the equation of motion of the electron is

$$m\ddot{\mathbf{x}} = e\mathbf{E}_{\text{wave}}(0, t) = e\hat{\mathbf{x}}E_0 \cos \omega t. \quad (12)$$

Using eq. (1) we find the position of the electron to be

$$\mathbf{x} = -\frac{e}{m\omega^2} \hat{\mathbf{x}}E_0 \cos \omega t. \quad (13)$$

The amplitude of this oscillation is, recalling the definition (2),

$$x_0 = \frac{eE_0}{m\omega^2} = \frac{eE_0}{m\omega c} \frac{c}{\omega} = \frac{\eta}{2\pi} \lambda \ll \lambda. \quad (14)$$

The velocity of the electron is

$$\mathbf{v} = \frac{eE_0}{m\omega} \hat{\mathbf{x}} \sin \omega t = \eta c \hat{\mathbf{x}} \sin \omega t, \quad (15)$$

and its kinetic energy is

$$T = \frac{m\dot{\mathbf{x}}^2}{2} = \frac{e^2 E_0^2}{2m^2 \omega^2} m \sin^2 \omega t = \frac{\eta^2}{2} mc^2 \sin^2 \omega t. \quad (16)$$

The time average of the total energy of the electron in the wave is

$$\bar{\mathcal{E}} = mc^2 \left(1 + \frac{\eta^2}{4} \right) \approx mc^2 \sqrt{1 + \eta^2/2} \equiv \bar{m}c^2, \quad (17)$$

where $\bar{m} = m\sqrt{1 + \eta^2/2}$ in a view that averages over the “microscopic” motion of the electron within the wave. That is, the “background” electromagnetic field has “given mass” to the electron beyond the mass m in zero field.

Longitudinal Motion of the Electron

In the weak-field approximation, we can now use eq. (15) for the velocity to evaluate the second term of the Lorentz force:

$$e\frac{\mathbf{v}}{c} \times \mathbf{B} = \frac{e^2 E_x^2}{2m\omega c} \hat{\mathbf{z}} \sin 2\omega t = m\ddot{\mathbf{z}}. \quad (18)$$

This term vanishes for circular polarization, in which case the motion is wholly in the transverse plane. However, for linear polarization the $\mathbf{v}/c \times \mathbf{B}$ force leads to oscillations along the z axis at frequency 2ω , as first analyzed in general by Landau.⁷ For polarization along the $\hat{\mathbf{x}}$ axis, the x - z motion has the form of a “figure 8”, which for weak fields ($\eta \ll 1$) is described by

$$x = -\frac{\eta}{2\pi} \lambda \cos \omega t, \quad z = -\frac{e^2 E_x^2}{8m^2 \omega^3 c} \sin 2\omega t = -\frac{\eta^2}{16\pi} \lambda \sin 2\omega t. \quad (19)$$

If the electron had been at rest before the arrival of the plane wave, then inside the wave it would move with an average drift velocity given by

$$v_z = \frac{\eta^2/2}{1 + \eta^2/2} c, \quad (20)$$

along the direction of the wave vector, as first deduced by McMillan.⁸ Here, we work in the frame in which the electron has no average velocity along the z axis. Therefore, prior to its encounter with the plane wave the electron had been moving in the negative z direction with speed given by eq. (20).

The energy and momentum of the electron are compensated by changes in the electromagnetic energy and momentum associated with the interaction of the plane wave fields and the fields of the oscillating charge. For further discussion, see

<http://physics.princeton.edu/~mcdonald/examples/transmom2.pdf>

<http://physics.princeton.edu/~mcdonald/accel/acceleration2.pdf>

3. Synchrotron Radiation

The Critical Frequency

An important fact about synchrotron radiation is that the frequency spectrum peaks near the critical frequency, ω_C , which depends on the radius R of curvature of the electron’s trajectory, and on the Lorentz factor γ via

$$\omega_C \approx \gamma^3 \frac{c}{R}. \quad (21)$$

⁷L. Landau and E.M. Lifshitz, *The Classical Theory of Fields*, 4th ed. (Pergamon Press, Oxford, 1975), prob. 2, § 47 and prob. 2, § 49; p. 112 of the 1941 Russian edition,

http://physics.princeton.edu/~mcdonald/examples/EM/landau_teoría_polya_41.pdf

⁸E.M. McMillan, *The Origin of Cosmic Rays*, Phys. Rev. **79**, 498-501 (1950),

http://physics.princeton.edu/~mcdonald/examples/accel/mcmillan_pr_79_498_50.pdf

Since $\omega_0 = c/R$ is the angular velocity for particles with velocity near the speed of light, synchrotron radiation occurs at very high harmonics of this fundamental frequency. The wavelength at the critical frequency is then

$$\lambda_C \approx \frac{R}{\gamma^3}. \quad (22)$$

For completeness, we sketch a well-known argument leading to eq. (21). The characteristic frequency ω_C is the reciprocal of the pulselength of the radiation from a single electron according to an observer at rest in the lab. In the case of motion in a circle, the electron emits a cone of radiation of angular width $\theta = 1/\gamma$ according to eq. (7) that rotates with angular velocity $\omega = c/R$. Light within this cone reaches the fixed observer during time interval $\delta t' = \theta/\omega \approx R/\gamma c$. However, this time interval measures the retarded time t' at the source, not the time t at the observer. Both t and t' are measured in the lab frame, and are related by $t' = t - r/c$ where r is the distance between the source and observer. When the source is heading towards the observer, we have $\delta r = -v\delta t'$, so $\delta t = \delta t'(1 - v/c) \approx \delta t'/2\gamma^2 \approx R/\gamma^3 c$, from which eq. (21) follows.

The Formation Length

The formation length L_0 introduced in eq. (9) applies for radiation processes during which the electron moves along a straight line, such as Čerenkov radiation and transition radiation. But, synchrotron radiation occurs when the electron moves in the arc of a circle of radius R . During the formation time, the electron moves by formation angle $\theta_0 = L_0/R$ with respect to the center of the circle. We now reconsider the derivation of the formation time, noting that while the electron moves on the arc $R\theta_0 = vt_0$ of the circle, the radiation moves on the chord $2R \sin(\theta_0/2) \approx R\theta_0 - R\theta_0^3/24$. Hence,

$$\begin{aligned} \lambda &= ct_0 - \text{chord} \approx \frac{cR\theta_0}{v} - R\theta_0 + \frac{R\theta_0^3}{24} \\ &\approx R\theta_0(1 - \beta) + \frac{R\theta_0^3}{24} \approx \frac{R\theta_0}{2\gamma^2} + \frac{R\theta_0^3}{24}, \end{aligned} \quad (23)$$

for radiation observed at small angles to the chord.

For wavelengths longer than λ_C , the formation angle grows large compared to the characteristic angle $\theta_C \approx 1/\gamma$, and the first term of eq. (23) can be neglected compared to the second. In this case,

$$\theta_0 \approx \left(\frac{\lambda}{R}\right)^{1/3} \approx \frac{1}{\gamma} \left(\frac{\lambda}{\lambda_C}\right)^{1/3} \quad (\lambda \gg \lambda_C), \quad (24)$$

and

$$L_0 \approx R^{2/3} \lambda^{1/3} \approx \gamma^2 \lambda_C \left(\frac{\lambda}{\lambda_C}\right)^{1/3} \quad (\lambda \gg \lambda_C), \quad (25)$$

using eq. (22).

The formation angle $\theta_0(\lambda)$ can also be interpreted as the characteristic angular width of the radiation pattern at this wavelength. A result not deducible from the simplified arguments given above is that for $\lambda \gg \lambda_C$, the angular distribution of synchrotron radiation falls off exponentially: $dU(\lambda)/d\Omega \propto e^{-\theta^2/2\theta_0^2}$. See, for example, sec. 14.6 of [5].

For wavelengths much less than λ_C , the formation length is short, the formation angle is small, and the last term of eq. (23) can be neglected. Then, we find that

$$\theta_0 \approx \frac{\lambda}{\gamma\lambda_C}, \quad L_0 \approx \gamma^2\lambda \quad (\lambda \ll \lambda_C), \quad (26)$$

the same as for motion along a straight line, eq. (10). In this limit, our approximation neglects the curvature of the particle's trajectory, which is an essential aspect of synchrotron radiation, and we cannot expect our analysis to be very accurate. But for $\lambda \ll \lambda_C$, the rate of radiation is negligible.

Of greater physical interest is the region $\lambda \approx \lambda_C$ where the frequency spectrum begins to be exponentially damped but the rate is still reasonably high. The cubic equation (23) does not yield a simple analytic result in the region. So, we interpolate between the limiting results for θ_0 at large and small wavelengths, eqs. (24) and (26), and estimate that

$$\theta_0 \approx \frac{1}{\gamma} \sqrt{\frac{\lambda}{\lambda_C}} \quad (\lambda \approx \lambda_C), \quad (27)$$

which agrees with a more detailed analysis [5]. The corresponding formation length $R\theta_0$ is then

$$L_0 \approx \gamma^2 \sqrt{\lambda\lambda_C} \quad (\lambda \approx \lambda_C). \quad (28)$$

Digression: Transverse Coherence Length

The longitudinal origin of radiation is uncertain to within one formation length L_0 . Over this length, the trajectory of the electron is curved, so there is an uncertainty in the transverse origin of the radiation as well. A measure of the transverse uncertainty is the sagitta $L_0^2/8R$, which we label w_0 anticipating a useful analogy with the common notation for the waist of a focused laser beam. For $\lambda \gg \lambda_C$, we have from eq. (25),

$$w_0 \approx \frac{L_0^2}{R} \approx R^{1/3}\lambda^{2/3} \approx \gamma\lambda_C \left(\frac{\lambda}{\lambda_C}\right)^{2/3} \quad (\lambda \gg \lambda_C). \quad (29)$$

The sagitta (29) is larger than the minimum transverse length (6), so we expect that the full virtual photon cloud is shaken off over one formation length.

For $\lambda \gg \lambda_C$, the characteristic angular spread (24) of the radiation obeys

$$\theta_0 \approx \frac{\lambda}{w_0}, \quad (30)$$

consistent with the laws of diffraction. Hence, the distance w_0 of eq. (29) can also be called the **transverse coherence length** [11] of the source of synchrotron radiation.

The analogy with laser notation is also consistent with identifying the formation length L_0 with the Rayleigh range $z_0 = w_0/\theta_0$, since we see that

$$L_0 \approx \frac{\lambda}{\theta_0^2} \approx \frac{w_0}{\theta_0}. \quad (31)$$

A subtle difference between the radiation of a relativistic charge and a focused laser beam is that the laser beam has a Gouy phase shift [12, 13] between its waist and the far field, while radiation from a charge does not.

For $\lambda \approx \lambda_C$, the sagitta is $L_0^2/R \approx \gamma^2 \lambda$, using eq. (28). When $\lambda < \lambda_C$, the characteristic angle θ_0 given by eq.(27) is less than $\lambda/\text{sagitta}$, and the sagitta is no longer a good measure of the transverse coherence length, which is better defined as $\lambda/\theta_0 \approx \gamma\sqrt{\lambda\lambda_C}$.

Frequency Spectrum

The number of photons radiated per unit path length l during synchrotron radiation is obtained from the Weizsäcker-Williams spectrum (11) using eqs. (25) and (28) for the formation length:

$$\frac{dn_\omega}{dl} \approx \begin{cases} \alpha\omega_C^{2/3} d\omega/\gamma^2 c\omega^{2/3} & (\lambda \gg \lambda_C), \\ \alpha\omega_C^{1/2} e^{-\omega/\omega_C} d\omega/\gamma^2 c\omega^{1/2} & (\lambda \lesssim \lambda_C). \end{cases} \quad (32)$$

We multiply by $\hbar\omega$ to recover the energy spectrum:

$$\frac{dU(\omega)}{dl} \approx \begin{cases} e^2\omega_C^{2/3} \omega^{1/3} d\omega/\gamma^2 c^2 & (\lambda \gg \lambda_C), \\ e^2\omega_C^{1/2} \omega^{1/2} e^{-\omega/\omega_C} d\omega/\gamma^2 c^2 & (\lambda \lesssim \lambda_C). \end{cases} \quad (33)$$

Thus, the Weizsäcker-Williams method shows that the energy spectrum varies as $\omega^{1/3}$ at low frequencies, and as $\sqrt{\omega}e^{-\omega/\omega_C}$ at frequencies above the critical frequency $\omega_C = \gamma^3 c/R$.

The total radiated power is estimated from eq. (33) using $\omega \approx d\omega \approx \omega_C \approx \gamma^3 c/R$, and multiplying by $v \approx c$ to convert dl to dt :

$$\frac{dU}{dt} \approx \frac{e^2\gamma^4 c}{R^2}. \quad (34)$$

This well-known result is also obtained from the Larmor formula, $dU/dt = 2e^2 a^{*2}/3c^2$, where the rest-frame acceleration is given by $a^* = \gamma^2 a \approx \gamma^2 c^2/R$ in terms of lab quantities.

For discussion of undulator radiation, transition radiation, and Čerenkov radiation via the Weizsäcker-Williams method, see

<http://physics.princeton.edu/~mcdonald/examples/weizsacker.pdf>

The Weizsäcker-Williams method can also be used to characterize the radiation from a single oscillating electric charge.⁹ The radiation associated with a current pulse that

⁹K.T. McDonald and M.S. Zolotarev, *Hertzian Dipole Radiation via the Weizsäcker-Williams Method* (Aug. 4, 2003), <http://physics.princeton.edu/~mcdonald/examples/hertzian.pdf>

propagates along a conductor and reflects off its end is much like that of an electric charge that has the same velocity ($\approx c$) as the pulse (even though the velocities of the charges in the conductor are much less than c).¹⁰

The author has used the Weizsäcker-Williams approximation to estimate the cross section for the nonlinear QED trident process $e + n\omega_0 \rightarrow e' + e^+e^-$, where a high-energy electron interacts with an intense laser beam of angular frequency ω_0 ,

<http://physics.princeton.edu/~mcdonald/examples/trident.pdf>

4. This problem is due to Iwanenko and Pomeranchuk.¹¹

The electron is held in its circular orbit by the Lorentz force due to the field B . Newton's law, $F = ma$, for this circular motion can be written (in Gaussian units)

$$F = \gamma m a = \frac{\gamma m v^2}{R} = e \frac{v}{c} B. \quad (35)$$

For a relativistic electron, $v \approx c$, so we have

$$\gamma \approx \frac{eRB}{mc^2}. \quad (36)$$

The electron is being accelerated by the electric field that is induced by the changing magnetic flux. Applying the integral form of Faraday's law to the circle of radius R , we have (ignoring the sign)

$$2\pi R E_\phi = \frac{\dot{\Phi}}{c} = \frac{\pi R^2 \dot{B}_{\text{ave}}}{c}, \quad (37)$$

and hence,

$$E_\phi = \frac{R \dot{B}_{\text{ave}}}{2c}, \quad (38)$$

The rate of change of the electron's energy \mathcal{E} due to E_ϕ is

$$\frac{d\mathcal{E}}{dt} = \mathbf{F} \cdot \mathbf{v} \approx ecE_\phi = \frac{eR \dot{B}_{\text{ave}}}{2}, \quad (39)$$

Since $\mathcal{E} = \gamma mc^2$, we can write

$$\dot{\gamma} mc^2 = \frac{eR \dot{B}_{\text{ave}}}{2}, \quad (40)$$

which integrates to

$$\gamma = \frac{eR B_{\text{ave}}}{2mc^2}. \quad (41)$$

¹⁰T.W. Hertel and G.S. Smith, *Pulse Radiation from an Insulated Antenna: An Analog of Cherenkov Radiation from a Moving Charged Particle*, IEEE Trans. Ant. Prop. **48**, 165 (2000), http://physics.princeton.edu/~mcdonald/examples/EM/hertel_ieeetap_48_165_00.pdf

¹¹D. Iwanenko and I. Pomeranchuk, *On the Maximal Energy Attainable in a Betatron*, Phys. Rev. **65**, 343 (1944), http://physics.princeton.edu/~mcdonald/examples/accel/iwanenko_pr_65_343_44.pdf

Comparing with eq. (36), we find the required condition on the magnetic field:

$$B = \frac{B_{\text{ave}}}{2}. \quad (42)$$

As the electron accelerates it radiates energy at rate given by the Larmor formula in the rest frame of the electron,

$$\frac{d\mathcal{E}^*}{dt^*} = -\frac{2e^2\dot{p}^{*2}}{3c^3} = -\frac{2e^2a^{*2}}{3c^3} \quad (43)$$

Because \mathcal{E} and t are both the time components of 4-vectors their transforms from the rest frame to the lab frame have the same form, and the rate $d\mathcal{E}/dt$ is invariant. However, acceleration at right angles to velocity transforms according to $a^* = \gamma^2 a$. Hence, the rate of radiation in the lab frame is

$$\frac{d\mathcal{E}}{dt} = -\frac{2e^2\gamma^4 a^2}{3c^3} = -\frac{2e^4\gamma^2 B^2}{3m^2 c^3}, \quad (44)$$

using eq. (35) for the acceleration a .

The maximal energy of the electrons in the betatron obtains when the energy loss (44) cancels the energy gain (39), *i.e.*, when

$$\frac{eR\dot{B}_{\text{ave}}}{2} = \frac{2e^4\gamma_{\text{max}}^2 B^2}{3m^2 c^3}, \quad (45)$$

and

$$\gamma_{\text{max}} = \sqrt{\frac{3m^2 c^3 R \dot{B}_{\text{ave}}}{4e^3 B^2}} = \sqrt{\frac{3R}{4\alpha c} \frac{\dot{B}_{\text{ave}}}{B} \frac{B_{\text{crit}}}{B}} \approx \sqrt{\frac{3R}{4\alpha c\tau} \frac{B_{\text{crit}}}{B}}, \quad (46)$$

where $\alpha = e^2/\hbar c = 1/137$ is the fine structure constant, $B_{\text{crit}} = m^2 c^3/e\hbar = 4.4 \times 10^{13}$ G is the so-called QED critical field strength, and τ is the characteristic cycle time of the betatron such that $\dot{B}_{\text{ave}} = B/\tau$. For example, with $R = 1$ m, $\tau = 0.03$ sec (30 Hz), and $B = 10^4$ G, we find that $\gamma_{\text{max}} \approx 200$, or $\mathcal{E}_{\text{max}} \approx 100$ MeV.

We have ignored the radiation due to the longitudinal acceleration of the electron, since in the limiting case this acceleration ceases.

For discussion of the stability of the motion of electrons in a betatron, see

http://physics.princeton.edu/~mcdonald/examples/betatron_osc.pdf.

5. The Lorentz force on a magnetic monopole of magnetic charge g is¹²

$$\mathbf{F} = g(\mathbf{B} - \boldsymbol{\beta} \times \mathbf{E}), \quad (47)$$

so the maximum force due to an electron (at rest) of charge $-e$ has magnitude

$$F_{\text{max}} = \frac{g\beta e}{b^2}, \quad (48)$$

¹²Discussion of the force law in case there were macroscopic densities of magnetic monopoles is given in <http://physics.princeton.edu/~mcdonald/examples/poynting.pdf>.

where b is the impact parameter of the monopole with the electron; The discussion now follows closely the case for an electrically charged particle.

The monopole experiences the peak force (48) for time $\Delta t \approx 2b/v$, and so receives an momentum impulse

$$\Delta p \approx F_{\max} \Delta t \approx \frac{2eg}{bc}, \quad (49)$$

from each electron independent of β .¹³ Each electron in the atom experiences an equal and opposite impulse, which corresponds to a gain of kinetic energy of¹⁴

$$\Delta E = \frac{\Delta p^2}{2m_e} \approx \frac{2e^2 g^2}{m_e b^2 c^2}. \quad (50)$$

The number of electrons per cm^2 in thickness dx is $N_0 Z dx/A$, where N_0 is Avagadro's number and A is the atomic number of the atom, such that the energy loss is

$$\frac{dE}{dx} = \frac{N_0 Z}{Z} \int_{b_{\min}}^{b_{\max}} 2\pi b db \frac{2e^2 g^2}{m_e b^2 c^2} = 4\pi N_0 \frac{Z}{A} \frac{e^2 g^2}{m_e c^2} \ln \frac{b_{\max}}{b_{\min}} \approx 4\pi N_0 \frac{Z}{A} \frac{e^2 g^2}{m_e c^2} \ln \frac{2m_e \gamma^2 v^2}{I}, \quad (51)$$

where the estimates for b_{\max} and b_{\min} are from p. 42, Lecture 4 of the Notes, $\gamma = 1/\sqrt{1 - \beta^2}$, and I is the ionization potential of the atom.

Comparing with the result for a passing particle of electrical charge e , we have for $\beta \approx 1$, and for the Dirac condition that $g = \hbar c/2e$,

$$\frac{dE_{\text{monopole}}/dx}{dE_{\text{charged}}/dx} = \frac{g^2}{e^2} = \left(\frac{\hbar c}{2e^2} \right)^2 = \frac{1}{4\alpha^2} \approx \frac{137^2}{4} \gg 1. \quad (52)$$

That is, the energy loss of relativistic magnetic monopole is very large compared to that of relativistic charged particles, so such monopoles should be easy to detect.

$\beta \approx 10^{-3}$.

For lower-speed monopoles we consider the effect of energy loss to Joule heating by Eddy currents induced in a metal plate as the monopole passes through it (with constant speed). The monopole moves along the z -axis and the plate is in the plane $z = 0$ (but with thickness T).

¹³This impulse is perpendicular to the plane that contains the electric charge and line of motion of the monopole. Hence, the electron takes on angular momentum $L \approx b\Delta p = 2eg/c$. This is consistent with the fact that the system of charge plus monopole contains nonzero field angular momentum of magnitude eg/c , directed along their line of centers (as first noted by J.J. Thomson, *On Momentum in the Electric Field*, Phil. Mag. **8**, 331 (1904), http://physics.princeton.edu/~mcdonald/examples/EM/thomson_pm_8_331_04.pdf). As the monopole passes the atom, the line of centers reverse direction, so the field angular momentum changes by $2eg/c$, such that total angular momentum is conserved. See also, J.S. Trefil, *A derivation of the classical monopole energy loss from angular momentum conservation*, Am. J. Phys. **51**, 1113 (1983), http://physics.princeton.edu/~mcdonald/examples/EP/trefil_ajp_51_1113_83.pdf.

¹⁴The atomic nucleus gains negligible energy, as discussed on p. 41, Lecture 4 of the Notes.

The fields of a monopole with uniform velocity \mathbf{v} are the duals of those of a moving electron,¹⁵

$$\mathbf{B} = \frac{g\hat{\mathbf{R}}}{\gamma^2 R^2 (1 - \beta^2 \sin^2 \theta)^{3/2}}, \quad \mathbf{E} = -\boldsymbol{\beta} \times \mathbf{B}, \quad (53)$$

where \mathbf{R} is the (instantaneous) vector from the monopole to the observer, and θ is the angle between \mathbf{v} and \mathbf{R} . When the monopole is at $(x, y, z) = (0, 0, vt)$ above the plate, and moving with velocity $\mathbf{v} = v\hat{\mathbf{z}}$, its (azimuthal) electric field at a point at radius r in the plane $z = 0$ is

$$E_\phi = \frac{\beta gr}{\gamma^2 (r^2 + z^2)^{3/2} [1 - \beta^2 r^2 / (r^2 + z^2)]^{3/2}} = \frac{\beta gr}{\gamma^2 (r^2 + z^2 - \beta^2 r^2)^{3/2}} \\ \approx \begin{cases} 0 & \gamma \gg 1, \\ \beta gr / (r^2 + z^2)^{3/2} & \beta \ll 1. \end{cases} \quad (54)$$

We see that the Eddy-current effects will be negligible for relativistic monopoles.

Another derivation starts from the z -component of the magnetic field,

$$B_z = \frac{gz}{\gamma^2 (r^2 + z^2)^{3/2} [1 - \beta^2 r^2 / (r^2 + z^2)]^{3/2}} = \frac{gz}{\gamma^2 (r^2 + z^2 - \beta^2 r^2)^{3/2}} \\ \approx \begin{cases} 0 & \gamma \gg 1, \\ gz / (r^2 + z^2)^{3/2} & \beta \ll 1. \end{cases} \quad (55)$$

Continuing with the nonrelativistic case, the magnetic flux Φ through a ring of radius r in the plate is

$$\Phi = \int_0^r 2\pi r dr B_z = \int_0^r 2\pi r dr \frac{gz}{(r^2 + z^2)^{3/2}} = 2\pi g \left(1 - \frac{z}{\sqrt{r^2 + z^2}} \right). \quad (56)$$

The changing magnetic flux results in an azimuthal electric field around the ring according to Faraday's law,

$$E_\phi = -\frac{1}{2\pi r c} \frac{d\Phi}{dt} = \frac{g\beta}{r} \left(\frac{1}{(r^2 + z^2)^{1/2}} - \frac{z^2}{(r^2 + z^2)^{3/2}} \right) = \frac{\beta gr}{(r^2 + z^2)^{3/2}}, \quad (57)$$

as found above.

This electric field leads to current density $J_\phi = \sigma E_\phi = E_\phi / \rho$, where ρ is the resistivity of the plate, and the power density dissipated by this current $\mathbf{J} \cdot \mathbf{E} = E_\phi^2 / \rho$. However, the electric field diverges at $r = 0$ as the monopole passes through the plate, so the Joule heating would be infinite if it exists on very small length scales. We recall that in the

¹⁵See, for example, p. 223a of <http://physics.princeton.edu/~mcdonald/examples/ph501/ph501lecture18.pdf>.

Drude model, Joule heating is associated with inelastic collisions between conduction electrons and the “lattice,” such that,¹⁶

$$\sigma = \frac{1}{\rho} = \frac{ne^2\tau}{2m_e}, \quad (58)$$

where n is the number density of conduction electrons and τ is the characteristic collision time. If the conduction electrons have microscopic average velocity denoted by v_{Fermi} , then Joule heating is not meaningful for distances less than

$$r_{\text{min}} \approx v_{\text{Fermi}}\tau = \frac{2m_e v_{\text{Fermi}}}{ne^2\rho}. \quad (59)$$

The total energy dissipated in the resistive plate as the monopole moves according to $z = vt$ is

$$\begin{aligned} U &= \int_{-\infty}^{\infty} dt \int \frac{E_{\phi}^2}{\rho} d\text{Vol} = \int_{-\infty}^{\infty} \frac{v dt}{v} \int_{r_{\text{min}}}^{\infty} 2\pi r T dr \frac{g^2\beta^2}{\rho} \frac{r^2}{(r^2 + v^2t^2)^3} \\ &= \frac{2\pi g^2\beta T}{c\rho} \int_{r_{\text{min}}}^{\infty} r^3 dr \frac{3\pi}{8r^5} = \frac{3\pi^2 g^2\beta T}{4c\rho} \frac{1}{r_{\text{min}}} = \frac{3\pi^2 n (eg)^2 \beta T}{8m_e c^2 \beta_{\text{Fermi}}}. \end{aligned} \quad (60)$$

For monopoles that obey the Dirac condition, $eg = \hbar c/2$, we have that energy loss is

$$\frac{dE}{dx} = \frac{U}{T} = \frac{3\pi^2 n (\hbar c)^2}{32m_e c^2} \frac{\beta}{\beta_{\text{Fermi}}} = \frac{3\pi^2 n r_e^2 m_e c^2}{32} \frac{\beta}{\beta_{\text{Fermi}}}, \quad (61)$$

where here dE/dx has units of energy/cm, and $r_e = e^2/m_e c^2$ is the classical electron radius.

For further discussion, see S.P. Ahlen and K. Kinoshita, *Calculation of the stopping power of very-low-velocity magnetic monopoles*, Phys. Rev. D **26**, 2347 (1982),

http://physics.princeton.edu/~mcdonald/examples/detectors/ahlen_prd_26_2347_82.pdf.

¹⁶See, for example, p. 76 of <http://physics.princeton.edu/~mcdonald/examples/ph501/ph501lecture7.pdf>.