

Resistive Cylinder Moving in an External, Static Magnetic Field

Kirk T. McDonald

Joseph Henry Laboratories, Princeton University, Princeton, NJ 08544

(November 2, 2011)

1 Problem

A static magnetic field completely penetrates a resistive conductor that is at rest. Discuss the case that the conductor is a cylinder with uniform velocity $v \ll c$ perpendicular to its axis and to the direction of the external magnetic field, where c is the speed of light in vacuum.

Discuss the flow of energy in a dynamo based on a resistive cylinder that slides on a U-shaped track in a transverse magnetic field.

2 Solution

The cylinder has radius a , resistivity ρ , and its axis, which is parallel to the z -axis, moves with velocity $\mathbf{v} = v \hat{\mathbf{y}}$, where v is small compared to the speed of light c . The external magnetic field in the lab frame is $\mathbf{B}_0 = B_0 \hat{\mathbf{x}}$.

2.1 Analysis in the Rest Frame of the Cylinder

In the rest frame of the resistive cylinder (where quantities are denoted with the superscript ') the external field includes both electric and magnetic components, which are for $v \ll c$ and in Gaussian units,

$$\mathbf{E}'_0 \approx \mathbf{E}_0 + \frac{\mathbf{v}}{c} \times \mathbf{B}_0 = -\frac{v}{c} B_0 \hat{\mathbf{z}}, \quad \mathbf{B}'_0 \approx \mathbf{B}_0 - \frac{\mathbf{v}}{c} \times \mathbf{E}_0 = B_0 \hat{\mathbf{x}}, \quad (1)$$

as $\mathbf{E}_0 = 0$. The axial electric field in the rest frame of the cylinder drives an axial current density inside the cylinder given by

$$\mathbf{J}'(r' < a) = \frac{\mathbf{E}'_0}{\rho} = -\frac{v B_0}{c \rho} \hat{\mathbf{z}} \equiv -\frac{I_0}{\pi a^2} \hat{\mathbf{z}}, \quad i.e., \quad I_0 = \frac{\pi a^2 v B_0}{c \rho} = \frac{v B_0}{c R_0}, \quad (2)$$

where (r', θ', z) are cylindrical coordinates with origin at the axis of the cylinder, ρ is the resistivity of the cylinder, I_0 is the total current (defined to be positive), and $R_0 = \rho/\pi a^2$ is the resistance per unit length of the cylinder along its axis.¹ This current creates an azimuthal magnetic field in the rest frame of the cylinder given by

$$\mathbf{B}'_{\theta'} = -\hat{\theta}' \begin{cases} \frac{2r' I_0}{a^2 c} = \frac{2\pi r' v B_0}{c^2 \rho} & (r' < a), \\ \frac{2I_0}{c r'} = \frac{2\pi a^2 v B_0}{c^2 r' \rho} & (r' > a). \end{cases} \quad (3)$$

¹The current flows only if the cylinder is connected to some return current path at “infinity” (whose resistivity is small compared to ρ). A cylinder of finite length (with no return-current path) would develop a charge separation that produces an electric field $-\mathbf{E}'_0$ inside the cylinder, after which no current flows.

Because the static field \mathbf{B}'_0 penetrates the resistive cylinder, the current density (2) experiences a Biot-Savart force density

$$\mathbf{f}' = \frac{\mathbf{J}'}{c} \times (\mathbf{B}'_0 + \mathbf{B}'_{\theta'}) = -\frac{vB_0^2}{c^2\rho} \hat{\mathbf{y}} - \frac{2rI_0^2}{\pi a^4 c^2} \hat{\mathbf{r}}' \approx -\frac{I_0^2 R_0}{\pi a^2 v} \hat{\mathbf{y}}. \quad (4)$$

The radial force is of order v^2/c^2 and will be ignored here.² The transverse force component f'_y was first identified by Hall [2], who realized that for steady flow of (negative) charge carriers with drift velocity $\mathbf{v}_d = v_d \hat{\mathbf{z}}$ (and negative charge density ρ^- such that $J'z = \rho^- v_d$) there must be a transverse electric field,^{3,4}

$$\mathbf{E}'_H(r' < a) = -\frac{\mathbf{v}_d}{c} \times \mathbf{B}'_0 = -\frac{v_d B_0}{c} \hat{\mathbf{y}} = -\frac{v_d B_0}{c} (\sin \theta' \hat{\mathbf{r}}' + \cos \theta' \hat{\boldsymbol{\theta}}'). \quad (5)$$

This field, which is uniform inside the cylinder, is established by a surface charge density

$$\sigma' = \frac{v_d B_0 \sin \theta'}{2\pi c}, \quad (6)$$

on comparing, for example, with sec. 2 of [4]. Outside the cylinder, the Hall field is

$$\mathbf{E}'_H(r' > a) = -\frac{v_d B_0 a^2}{c r'^2} (-\sin \theta' \hat{\mathbf{r}}' + \cos \theta' \hat{\boldsymbol{\theta}}'). \quad (7)$$

The electric field \mathbf{E}' does work per unit length on the current density \mathbf{J}' at the rate

$$P'_E = \int_0^a dr' \int_0^{2\pi} r' d\theta' \mathbf{J}' \cdot \mathbf{E}' = \pi a^2 J' E'_0 = \pi a^2 \rho J'^2 = \frac{\rho I_0^2}{\pi a^2} = I_0^2 R_0, \quad (8)$$

which equals the power per unit length dissipated in the resistance of the cylinder. *The magnetic force density $\mathbf{f}'_B = \mathbf{J}'/c \times \mathbf{B}' = \rho^- \mathbf{v}_d/c \times \mathbf{B}'$ does work at the rate $\mathbf{v}_d \cdot \mathbf{f}' = 0$.*

The Poynting vector just outside the surface of the cylinder in the rest frame is

$$\begin{aligned} \mathbf{S}'(r' = a^+) &= \frac{c}{4\pi} \mathbf{E}'(r' = a^+) \times \mathbf{B}'(r' = a^+) = \frac{c}{4\pi} (\mathbf{E}'_0 + \mathbf{E}'_H) \times (\mathbf{B}'_0 + \mathbf{B}'_{\theta'}) \\ &\approx \frac{c}{4\pi} \left(\frac{-vB_0}{c} \hat{\mathbf{z}} - \frac{v_d B_0 a^2}{c r'^2} (-\sin \theta' \hat{\mathbf{r}}' + \cos \theta' \hat{\boldsymbol{\theta}}') \right) \\ &\quad \times \left(B_0 (\cos \theta' \hat{\mathbf{r}}' - \sin \theta' \hat{\boldsymbol{\theta}}') - \frac{2I_0}{ac} \hat{\boldsymbol{\theta}}' \right) \\ &= -\frac{vB_0^2}{4\pi} (\sin \theta' \hat{\mathbf{r}}' + \cos \theta' \hat{\boldsymbol{\theta}}') - \frac{I_0^2 R_0}{2\pi a} \hat{\mathbf{r}}' - \left(\frac{v_d B_0^2 \cos 2\theta'}{4\pi} - \frac{v_d B_0 I_0 \sin \theta'}{2\pi ac} \right) \hat{\mathbf{z}}. \end{aligned} \quad (9)$$

²At order v^2/c^2 there must be a net volume charge density in the cylinder to cancel this force. This illustrates that a current-carrying wire is not electrically neutral in its rest frame. See, for example, [1].

³The Hall field (5) leads to a voltage difference $2av_d B_0/c$ across a diameter of the wire in y , which permits determination of the drift velocity v_d .

⁴See [3] for a discussion of the relation between the Hall field (5) and the Lorentz force (4) felt by the lattice ions of the sliding bar.

The total electromagnetic power flowing into the cylinder per unit length in z is

$$P_0 = - \int_0^{2\pi} S'_{r'}(r' = a^+) a d\theta' = I_0^2 R_0 = P'_E, \quad (10)$$

which provides the power that the electric field delivers to the current density \mathbf{J}' .

This power is dissipated in Joule heating, $P_{\text{Joule}} = I_0^2 R_0 = P_0$ per unit length, which power cannot come from a mechanical force on the cylinder, as it is at rest. The power must come from an electromagnetic source, as suggested by eqs. (9)-(10), but this source is not obvious.

Recall that the cylinder experiences a force \mathbf{F}' per unit length in the y -direction as given by πa^2 times the force density of eq. (4), *i.e.*, $\mathbf{F}' = -P_0 \hat{\mathbf{y}}/v$. This force is due to the external magnetic field, so we expect an electromagnetic reaction force $-\mathbf{F}'$ on the source of the external magnetic field, which source has velocity $-v \hat{\mathbf{y}}$ in the rest frame of the cylinder. The magnetic source is kept in steady motion by a mechanical force $\mathbf{F}_{\text{mech}} = -(-\mathbf{F}')$. Hence, the force on the magnetic source is doing mechanical work at the rate $P_{\text{mech}} = -v \hat{\mathbf{y}} \cdot \mathbf{F}_{\text{mech}} = P_0$.

In the rest frame we consider that the moving magnetic source acts as a transducer of mechanical power into electromagnetic power, which then flows into the resistive cylinder.

2.2 Quantities in the Lab Frame of the Cylinder

We now return to the lab frame, where the electric and magnetic fields are related to order v/c to their values in the rest frame by

$$\mathbf{E} \approx \mathbf{E}' - \frac{\mathbf{v}}{c} \times \mathbf{B}' \approx \mathbf{E}'_0 + \mathbf{E}'_H - \frac{\mathbf{v}}{c} \times (\mathbf{B}'_0 + \mathbf{B}'_{\theta'}) \approx \mathbf{E}_H + \mathbf{E}_v, \quad (11)$$

$$\mathbf{B} \approx \mathbf{B}' + \frac{\mathbf{v}}{c} \times \mathbf{E}' \approx \mathbf{B}'_0 + \mathbf{B}'_{\theta'} + \frac{\mathbf{v}}{c} \times (\mathbf{E}'_0 + \mathbf{E}'_H) \approx \mathbf{B}_0 + \mathbf{B}_{\theta'}, \quad (12)$$

where^{5,6}

$$\mathbf{E}_H = \mathbf{E}'_H = -\frac{v_d B_0}{c} \begin{cases} \sin \theta' \hat{\mathbf{r}}' + \cos \theta' \hat{\boldsymbol{\theta}}' = \hat{\mathbf{y}} & (r' < a), \\ \frac{a^2}{r'^2} (-\sin \theta' \hat{\mathbf{r}}' + \cos \theta' \hat{\boldsymbol{\theta}}') & (r' > a), \end{cases} \quad (13)$$

$$\mathbf{E}_v = -\frac{\mathbf{v}}{c} \times \mathbf{B}'_{\theta'} = \frac{2v I_0 \sin \theta'}{c^2} \hat{\mathbf{z}} \begin{cases} r'/a^2 & (r' < a), \\ 1/r' & (r' > a), \end{cases} \quad (14)$$

$$\mathbf{B}_0 = B_0 \hat{\mathbf{x}} = B_0 (\cos \theta' \hat{\mathbf{r}}' - \sin \theta' \hat{\boldsymbol{\theta}}'), \quad (15)$$

$$\mathbf{B}_{\theta'} = \mathbf{B}'_{\theta'} = -\hat{\boldsymbol{\theta}}' \begin{cases} \frac{2r' I_0}{a^2 c} = \frac{2\pi r' v B_0}{c^2 \rho} & (r' < a), \\ \frac{2I_0}{c r'} = \frac{2\pi a^2 v B_0}{c^2 r' \rho} & (r' > a). \end{cases} \quad (16)$$

⁵A common argument is that conduction electrons (of charge e), which have velocity component $v_y = v$ because of the motion of the cylinder, experience a Lorentz force $ev \hat{\mathbf{y}} \times \mathbf{B}_0/c = -evB_0 \hat{\mathbf{z}}/c$, which implies that there is an effective electric field $\mathbf{E}_v = -vB_0 \hat{\mathbf{z}}/c$, sometimes called the **motional** electric field.

⁶The field \mathbf{E}_v is also equal to $-\partial \mathbf{A}/\partial ct$, where \mathbf{A} is the time-dependent vector potential of the moving magnetic field $\mathbf{B}_{\theta'} \approx \mathbf{B}'_{\theta'}$ in the lab frame.

The bulk current density \mathbf{J} in the lab frame is related to quantities in the rest frame of the cylinder by

$$\mathbf{J} \approx \mathbf{J}' + \varrho' \mathbf{v} \approx \mathbf{J}' = -\frac{vB_0}{c\rho} \hat{\mathbf{z}}, \quad (17)$$

noting that the volume charge density ϱ' in the rest frame is of order v^2/c^2 . The volume charge density ϱ in the lab frame is given by

$$\varrho \approx \varrho' + \frac{\mathbf{v} \cdot \mathbf{J}'}{c^2} \approx 0. \quad (18)$$

There is a surface charge density on the cylinder in the lab frame, given by

$$\sigma \approx \sigma' + \frac{\mathbf{v} \cdot \mathbf{K}'}{c^2} = \sigma' = -\frac{v_d B_0 \sin \theta'}{2\pi c}, \quad (19)$$

since there is no surface current density \mathbf{K} on a resistive cylinder.

As a check, we verify that the current density obeys the “generalized Ohm’s Law,”

$$\begin{aligned} \mathbf{J} &= \frac{1}{\rho} \left(\mathbf{E} + \frac{\mathbf{v}_{\text{total}}}{c} \times \mathbf{B} \right) = \frac{1}{\rho} \left[(\mathbf{E}_H + \mathbf{E}_v) + \frac{\mathbf{v} + \mathbf{v}_d}{c} \times (\mathbf{B}_0 + \mathbf{B}_{\theta'}) \right] \\ &= \frac{1}{\rho} \left[\left(-\frac{\mathbf{v}_d}{c} \times \mathbf{B}_0 - \frac{\mathbf{v}}{c} \times \mathbf{B}_{\theta'} \right) + \frac{\mathbf{v} + \mathbf{v}_d}{c} \times (\mathbf{B}_0 + \mathbf{B}_{\theta'}) \right] \\ &= \frac{1}{\rho} \left(\frac{\mathbf{v}}{c} \times \mathbf{B}_0 + \frac{\mathbf{v}_d}{c} \times \mathbf{B}_{\theta'} \right) = -\frac{vB_0}{c\rho} \hat{\mathbf{z}} + \frac{2\pi r' v v_d B_0}{c^3 \rho} \hat{\mathbf{r}}' \approx -\frac{vB_0}{c\rho} \hat{\mathbf{z}}. \end{aligned} \quad (20)$$

In the lab frame the current density \mathbf{J} appears to be driven by the Lorentz force $\mathbf{v}/c \times \mathbf{B}_0$, and not by the electric field there. That is, the lab-frame electric field \mathbf{E} does work per unit length on the current density \mathbf{J} at the rate

$$P_E = \int_0^a dr' \int_0^{2\pi} r' d\theta' \mathbf{J} \cdot \mathbf{E} = 0. \quad (21)$$

The current density consists of flow of both positive and negative charges, $\mathbf{J} = \varrho^+ \mathbf{v} + \varrho^- (\mathbf{v} + \mathbf{v}_d) = \varrho^- \mathbf{v}_d$, as the cylinder is neutral. The work done by magnetic force density $\mathbf{J}/c \times \mathbf{B}$ must be calculated separately for the positive and negative densities as these have different velocities. Then, no work is done by the magnetic force density, since

$$\mathbf{v} \cdot \varrho^+ \mathbf{v}/c \times \mathbf{B} + (\mathbf{v} + \mathbf{v}_d) \cdot \varrho^- (\mathbf{v} + \mathbf{v}_d)/c \times \mathbf{B} = 0. \quad (22)$$

2.2.1 Forces on the Cylinder

Force is invariant under Lorentz transformations to order v/c , so the force per unit length on the cylinder in the lab frame is

$$\mathbf{F} = \mathbf{F}' = -\frac{P}{v} \hat{\mathbf{y}} = -\frac{I_0^2 R_0}{v} \hat{\mathbf{y}} = -\frac{B_0 I_0}{c} \hat{\mathbf{y}}. \quad (23)$$

That is, the total force per unit length on the cylinder is just the Biot-Savart force $\mathbf{I}_0 \times \mathbf{B}_0/c$ of the external magnetic field on the current.

If the cylinder is to move with constant velocity $v \hat{\mathbf{y}}$ the electromagnetic force (34) must be opposed by a mechanical force $\mathbf{F}_{\text{mech}} = B_0 I_0 \hat{\mathbf{y}}/c$, which does work on the moving cylinder at rate $P_{\text{mech}} = \mathbf{F}_{\text{mech}} \cdot \mathbf{v} = v B_0 I_0/c = I_0^2 R_0 = P_0$.

We verify eq. (23) via the Maxwell stress tensor T_{ij} , which relates to the force F_i on a surface element $d\text{Area}_j$ according to

$$F_i = \int \sum_k T_{ij} d\text{Area}_j, \quad (24)$$

where

$$T_{ij} = \frac{E_i D_j + B_i H_j}{4\pi} - \delta_{ij} \frac{\mathbf{E} \cdot \mathbf{D} + \mathbf{B} \cdot \mathbf{H}}{8\pi}. \quad (25)$$

The force on the cylinder is be given by the integral (24) over its surface, whose area element is $d\text{Area} = a d\theta' dz \hat{\mathbf{r}}'$. Hence, we need $T_{r'r'}$, $T_{\theta'r'}$ and $T_{zr'}$

We have from eqs. (3) and (14) that just outside the surface $r' = a$ of the moving cylinder,

$$\mathbf{E}(r' = a^+) = \mathbf{E}'_H + \mathbf{E}_v = \frac{v_d B_0}{c} \left(-\sin \theta' \hat{\mathbf{r}}' + \cos \theta' \hat{\boldsymbol{\theta}}' \right) + \frac{2v I_0 \sin \theta'}{ac^2} \hat{\mathbf{z}}, \quad (26)$$

$$\mathbf{B}(r' = a^+) = \mathbf{B}_0 + \mathbf{B}'_{\theta'} = B_0 \cos \theta' \hat{\mathbf{r}}' - \left(B_0 \sin \theta' + \frac{2I_0}{ac} \right) \boldsymbol{\theta}', \quad (27)$$

$$E^2 + B^2 = \frac{v_d^2 B_0^2}{c^2} + \frac{4v^2 I_0^2 \sin^2 \theta'}{a^2 c^4} + B_0^2 + \frac{4B_0 I_0}{ac} + \frac{4I_0^2}{a^2 c^2}, \quad (28)$$

and hence to order v/c ,

$$T_{r'r'} = \frac{1}{8\pi} \left[B_0^2 \left(\cos 2\theta' - \frac{v_d^2}{c^2} \sin 2\theta' \right) - \frac{4v^2 I_0^2 \sin^2 \theta'}{a^2 c^4} - \frac{4B_0 I_0}{ac} - \frac{4I_0^2}{a^2 c^2} \right], \quad (29)$$

$$T_{\theta'r'} = -\frac{1}{8\pi} \left[\left(1 - \frac{v_d^2}{c^2} \right) B_0^2 \sin 2\theta' + \frac{4B_0 I_0 \cos \theta'}{ac} \right], \quad (30)$$

$$T_{zr'} = 0. \quad (31)$$

The nonzero force elements on the surface are

$$dF_{r'} = T_{r'r'} d\text{Area}_{r'}, \quad dF_{\theta'} = T_{\theta'r'} d\text{Area}_{r'}. \quad (32)$$

The x - and y -force elements are related by

$$dF_x = dF_{r'} \cos \theta' - dF_{\theta'} \sin \theta', \quad \text{and} \quad dF_y = dF_{r'} \sin \theta' + dF_{\theta'} \cos \theta'. \quad (33)$$

Integrating over θ' , we find that $F_x = 0$, and

$$\frac{dF_y}{dz} = \int \frac{dF_{\theta'}}{dz} \cos \theta' = -\frac{1}{8\pi} \int_0^{2\pi} \frac{4B_0 I_0 \cos^2 \theta'}{c} d\theta' = -\frac{B_0 I_0}{c} = -\frac{P_0}{v}. \quad (34)$$

2.2.2 Flow of Energy

The Poynting vector outside the cylinder is

$$\begin{aligned}
\mathbf{S} &= \frac{c}{4\pi} \mathbf{E}(r' > a) \times \mathbf{B}(r' > a) = \frac{c}{4\pi} (\mathbf{E}_v + \mathbf{E}_H) \times (\mathbf{B}_0 + \mathbf{B}_{\theta'}) \\
&\approx \frac{c}{4\pi} \left(\frac{2vI_0 \sin \theta'}{c^2 r'} \hat{\mathbf{z}} + \frac{v_d B_0 a^2}{c r'^2} \left(-\sin \theta' \hat{\mathbf{r}}' + \cos \theta' \hat{\boldsymbol{\theta}}' \right) \right) \\
&\quad \times \left(B_0 \left(\cos \theta' \hat{\mathbf{r}}' - \sin \theta' \hat{\boldsymbol{\theta}}' \right) - \frac{2I_0}{c r'} \hat{\boldsymbol{\theta}}' \right) \\
&= \frac{I_0^2 R_0}{2\pi r'} (\sin^2 \theta' \hat{\mathbf{r}}' + \sin \theta' \cos \theta' \hat{\boldsymbol{\theta}}') + \frac{v I_0^2 \sin \theta'}{\pi c^2 r'^2} \hat{\mathbf{r}}' + \frac{v_d B_0 a^2}{2\pi r'^2} \left(\frac{B_0 \cos 2\theta'}{2} - \frac{I_0 \sin \theta'}{ac} \right) \hat{\mathbf{z}}.
\end{aligned} \tag{35}$$

The total electromagnetic power flowing outwards across a cylinder of radius $r' > a$, per unit length in z , is

$$P_{\text{EM}} = \int_0^{2\pi} S_{r'}(r' > a) r' d\theta' = \frac{I_0^2 R_0}{2}. \tag{36}$$

This cannot be! We need $P_{\text{EM}} = 0$ since we have already accounted in sec. 2.2.1 for the power dissipated per unit length, $I_0^2 R_0$, as equal to the rate of work done by the mechanical force that keeps the cylinder moving at constant velocity.

2.2.3 Stored Electromagnetic Energy

The density u of electromagnetic energy stored outside the cylinder is

$$u = \frac{E^2 + B^2}{8\pi} = \frac{B_0^2}{8\pi} \left(1 + \frac{v_d^2 a^2}{c^2 r'^4} \right) + \frac{B_0 I_0 \sin \theta'}{2\pi c r'} + \frac{I_0^2}{2\pi c^2 r'^2} \left(1 + \frac{v^2 \sin^2 \theta'}{c^2} \right). \tag{37}$$

We now check that eqs. (35) and (37) obey Poynting's theorem that $\nabla \cdot \mathbf{S} = -\partial u / \partial t$ outside the cylinder where $\mathbf{J} = 0$. For simplicity, we do this at time $t = 0$ when the axis of the cylinder is at $x = 0 = y$ and $r' = r$, $\theta' = \theta$. Then,

$$\nabla \cdot \mathbf{S}(t = 0) = \frac{1}{r} \frac{\partial(rS_r)}{\partial r} + \frac{1}{r} \frac{\partial S_\theta}{\partial \theta} + \frac{\partial S_z}{\partial z} = -\frac{v I_0^2 \sin \theta}{\pi c^2 r^3} + \frac{I_0^2 R_0 \cos 2\theta}{2\pi r^2}. \tag{38}$$

To take the time derivative of u we first note that

$$r' \cos \theta' = x' = x, \quad r' \sin \theta' = y' = y - vt, \quad r' = \sqrt{x^2 + (y - vt)^2}, \tag{39}$$

and hence,

$$\frac{\partial r'}{\partial t} = -v \sin \theta', \quad \frac{\partial \sin \theta'}{\partial t} = -\frac{v \cos^2 \theta'}{r'}. \tag{40}$$

Then,

$$\begin{aligned}
\frac{\partial u}{\partial t}(t = 0) &= -\frac{v v_d^2 a^2 B_0^2 \sin \theta}{2\pi c^2 r^5} - \frac{v B_0 I_0 \cos 2\theta}{2\pi c r^2} + \frac{v I_0^2 \sin \theta}{\pi c^2 r^3} \left(1 - \frac{v^2 \cos 2\theta}{c^2} \right) \\
&\approx -\frac{I_0^2 R_0 \cos 2\theta}{2\pi r^2} + \frac{v I_0^2 \sin \theta}{\pi c^2 r^3} = -\nabla \cdot \mathbf{S}(t = 0).
\end{aligned} \tag{41}$$

3 Use of a Resistive Cylinder in a Dynamo

A conceptually simple dynamo consists of a resistive cylinder that slides with velocity $v \hat{y}$ along a U-shaped track whose cross piece (of length l) is a resistive load R , subject to external magnetic field $B_0 \hat{x}$. as shown in the sketch below. For an interesting example of such a dynamo, see [5].

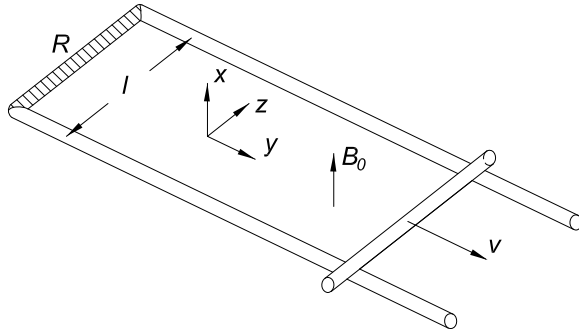

The magnetic flux through this partially moving circuit increases linearly with time, $\Phi_M = B_0 l v t$, so application of Faraday's law⁷ indicates that there should be an $\mathcal{EMF} = -B_0 l v / c$ around the circuit, which drives a clockwise current $I = B_0 l v / c R$.

If the moving conductor is an ordinary conductor with conductivity low enough that the external magnetic field completely penetrates it, then the conduction electrons, which have $v_y = v$ experience a Lorentz force $F_z = -e v B_0 / c$, that can be described as due to an effective electric field in the z -direction, $E_{\text{eff}} = -v B_0 / v$, where e is the charge on an electron. In this case, the system behaves as if there is an \mathcal{EMF} $\mathcal{E}_{\text{eff}} = \int E_{\text{eff}} dz = -v B_0 l / c$ between the points of contact of the sliding cylinder with the U-shaped track, where l is the separation between the two tracks of the U. Given a load resistance R (assumed for simplicity to be concentrated in the cross piece of the U), the total resistance in the circuit is $R_{\text{tot}} = R + l R_0$, current $I = v B_0 l / c R_{\text{tot}}$ flows in the circuit, and power $I^2 R_{\text{tot}}$ is dissipated by Joule heating.

The current I leads to an azimuthal magnetic field about the moving cylinder, such that the electric and magnetic fields just outside surface of the cylinder are (neglecting the effect on the cylinder of the fields due to the currents in the tracks for $a \ll l$),

$$\mathbf{B}_0 = \mathbf{B}'_0 = B_0 \hat{x} = B_0 (\cos \theta' \hat{r}' - \sin \theta' \hat{\theta}'), \quad (42)$$

$$\mathbf{B}_{\theta'}(r' = a^+) = \mathbf{B}'_{\theta'}(r' = a^+) = -\frac{2I}{ac} \hat{\theta}', \quad (43)$$

$$\mathbf{E}_H(r' = a^+) = \mathbf{E}'_H(r' = a^+) = \frac{v_d B_0}{c} (-\sin \theta' \hat{r}' + \cos \theta' \hat{\theta}'), \quad (44)$$

$$\mathbf{E}_v(r' = a^+) = -\frac{\mathbf{v}}{c} \times \mathbf{B}'_{\theta'}(r' = a^+) = \frac{2vI \sin \theta'}{ac^2} \hat{z}, \quad (45)$$

$$\mathbf{E}_{\parallel}(r' = a^+) = \rho \mathbf{J} - \frac{\mathbf{v}}{c} \times \mathbf{B}_0 = -\left(\frac{\rho I}{\pi a^2} - \frac{v B_0}{c}\right) \hat{z} = -(I - I_0) R_0 \hat{z}, \quad (46)$$

where the drift velocity $v_d \hat{z}$ of the electrons here is larger than that in sec. 2, and I_0 is the current (2) when $R = 0$. The field \mathbf{E}_{\parallel} , which drives the current $I - I_0$, is set up by a surface

⁷See [6] for discussion of the use of Faraday's law for circuits with moving parts.

charge density

$$\sigma_{\parallel}(z) = \frac{E_{\parallel}z}{2\pi a}, \quad (47)$$

taking $z = 0$ midway between the two tracks of the U.⁸

The lab-frame electric field \mathbf{E} does work the current density \mathbf{J} at the rate

$$P_E = l \int_0^a dr' \int_0^{2\pi} r' d\theta' \mathbf{J} \cdot \mathbf{E} = I(I - I_0)R_0l. \quad (48)$$

The Poynting vector $\mathbf{S}(r' = a^+)$ just outside the surface of the sliding bar is given by

$$\begin{aligned} \frac{4\pi}{c}\mathbf{S} &= (\mathbf{E}_H + \mathbf{E}_v + \mathbf{E}_{\parallel}) \times (\mathbf{B}_0 + \mathbf{B}_{\theta'}) \\ &= \mathbf{E}_H \times \mathbf{B}_0 + \mathbf{E}_v \times \mathbf{B}_0 + \mathbf{E}_{\parallel} \times \mathbf{B}_0 + \mathbf{E}_H \times \mathbf{B}_{\theta'} + \mathbf{E}_v \times \mathbf{B}_{\theta'} + \mathbf{E}_{\parallel} \times \mathbf{B}_{\theta'} \\ &= \frac{v_d B_0^2}{c} \cos 2\theta' \hat{\mathbf{z}} + \frac{2v_d B_0 I \sin \theta'}{ac^2} \left(\sin \theta' \hat{\mathbf{r}}' + \cos \theta' \hat{\boldsymbol{\theta}}' \right) - B_0(I - I_0)R_0 \left(\sin \theta' \hat{\mathbf{r}}' + \cos \theta' \hat{\boldsymbol{\theta}}' \right) \\ &\quad + \frac{2v_d B_0 I}{c} \cos \theta' \hat{\boldsymbol{\theta}}' + \frac{4vI^2}{a^2 c^3} \sin \theta' \hat{\mathbf{r}}' - \frac{2I(I - I_0)R_0}{ac} \hat{\mathbf{r}}'. \end{aligned} \quad (49)$$

The total power flowing off the moving cylinder is

$$P = l \int_0^{2\pi} S_{r'}(r' = a^+) a d\theta' = \frac{vB_0 l I}{2c} - I(I - I_0)R_0l = \frac{I^2 R_{\text{tot}}}{2} - I^2 R_0l + II_0 R_0l. \quad (50)$$

If $R = 0$ then $R_{\text{tot}} = R_0l$, $I = I_0$ and eq. (50) becomes eq. (36). Thus, the moving, resistive cylinder appears to be the source of the power, $I^2 R$ dissipated by the load resistor.

The current $\mathbf{I} = \pi a^2 \mathbf{J}$ in the cylinder experiences a Lorentz force

$$\mathbf{F} = l \mathbf{I}/c \times \mathbf{B}_0 = -\frac{l I B_0}{c} \hat{\mathbf{y}}. \quad (51)$$

To keep the cylinder in steady motion, some mechanical agent must provide an opposing force, which delivers energy into the system at rate

$$P_{\text{mech}} = -v F_y = \frac{l I v B_0}{c} = I^2 R_{\text{tot}}. \quad (52)$$

Thus, the moving cylinder acts as a transducer of mechanical power to electromagnetic power, according to the above analysis in the lab frame.⁹

⁸See sec. 3 of [4] for more details of the relation between a uniform axial field inside a cylinder and the surface charge density.

⁹The currents in this problem are steady, but the magnetic flux through the circuit varies with time, so we expect an \mathcal{EMF} in the (moving) circuit according to a broad interpretations of Faraday's law. The resulting power dissipated in the resistor agreeably flows in the form of electromagnetic energy out from the surface of the sliding bar. But this analysis gives no microscopic picture of how that energy flow arises.

3.1 Analysis in the Rest Frame of the Cylinder

In the rest frame of the cylinder the magnet that provides the external field $\mathbf{B}_0 = B_0 \hat{\mathbf{x}}$ has velocity $-v \hat{\mathbf{y}}$. This magnet exerts total force $\mathbf{F} = F_y \hat{\mathbf{y}}$ on the cylinder, so there is a reaction force $-\mathbf{F}$ on the magnet. A mechanical force $-\mathbf{F}$ is required in the lab frame to keep the magnet at rest there, and in the rest frame of the cylinder this force does work on the moving magnet at rate $-v \hat{\mathbf{y}} \cdot -\mathbf{F} = v F_y = I^2 R$. Thus, in the rest frame of the cylinder, we are led to say that the magnet acts as the transducer of mechanical power to electromagnetic power. This is an example of the relativity of steady energy flow (also discussed in [8]).

Acknowledgment

The author thanks Alan Boswell and Bruce Cragin for insightful e-discussions of this topic.

References

- [1] K.T. McDonald, *Charge Density in a Current-Carrying Wire* (Dec. 23, 2010), <http://physics.princeton.edu/~mcdonald/examples/wire.pdf>
- [2] E.H. Hall, *On the new Action of Magnetism on a permanent Electric Current*, Phil. Mag. **10**, 301 (1880), http://physics.princeton.edu/~mcdonald/examples/EM/hall_pm_10_301_80.pdf
- [3] W.R. McKinnon, S.P. McAlister and C.M. Hurd, *Origin of the force on a current-carrying wire in a magnetic field*, Am. J. Phys. **49**, 493 (1981), http://physics.princeton.edu/~mcdonald/examples/EM/mckinnon_ajp_49_493_81.pdf
- [4] K.T. McDonald, *Perfectly Conducting Cylinder in an External, Static Magnetic Field* (Oct. 29, 2011), http://physics.princeton.edu/~mcdonald/examples/perfect_cylinder.pdf
- [5] R.A. Sigelmann, *Tuning Fork Timepieces* (2005), http://physics.princeton.edu/~mcdonald/examples/EM/sigelmann_tuning_fork_timepieces.pdf
- [6] A. López-Ramos, J.R. Menéndez and C. Piqué, *Conditions for the validity of Faraday's law of induction and their experimental confirmation*, Eur. J. Phys. **29**, 1069 (2008), http://physics.princeton.edu/~mcdonald/examples/EM/lopez-ramos_ejp_29_1069_08.pdf
- [7] K.T. McDonald, *Where Does the Power Become AC in an AC Power Source?* (Feb. 27, 2007), <http://physics.princeton.edu/~mcdonald/examples/acpower.pdf>
- [8] K.T. McDonald, *Relativity of Steady Energy Flow* (Nov. 3, 2007), <http://physics.princeton.edu/~mcdonald/examples/1dgas.pdf>